



(19) **United States**

(12) **Patent Application Publication**
Zigmond et al.

(10) **Pub. No.: US 2008/0250445 A1**

(43) **Pub. Date: Oct. 9, 2008**

(54) **TELEVISION ADVERTISING**

Related U.S. Application Data

(75) Inventors: **Daniel J. Zigmond**, Menlo Park, CA (US); **Jason Bayer**, Mountain View, CA (US); **Greg Hecht**, Mountain View, CA (US); **Bryan McQuade**, Palo Alto, CA (US)

(60) Provisional application No. 60/909,893, filed on Apr. 3, 2007.

Publication Classification

(51) **Int. Cl.**
H04N 7/10 (2006.01)

(52) **U.S. Cl.** **725/32**

(57) **ABSTRACT**

Television advertisements and associated advertisement parameters are received from advertisers. The television advertisements are automatically selected for airing during an advertisement availability based on the associated advertisement parameters. Data related to the selected television advertisements are provided to a television provider to facilitate airing of the selected television advertisements during the advertisement availability. Reporting data related to television advertisement airings and impressions are received from the television provider.

Correspondence Address:
FISH & RICHARDSON P.C.
PO BOX 1022
MINNEAPOLIS, MN 55440-1022 (US)

(73) Assignee: **GOOGLE INC.**, Mountain View, CA (US)

(21) Appl. No.: **11/743,011**

(22) Filed: **May 1, 2007**

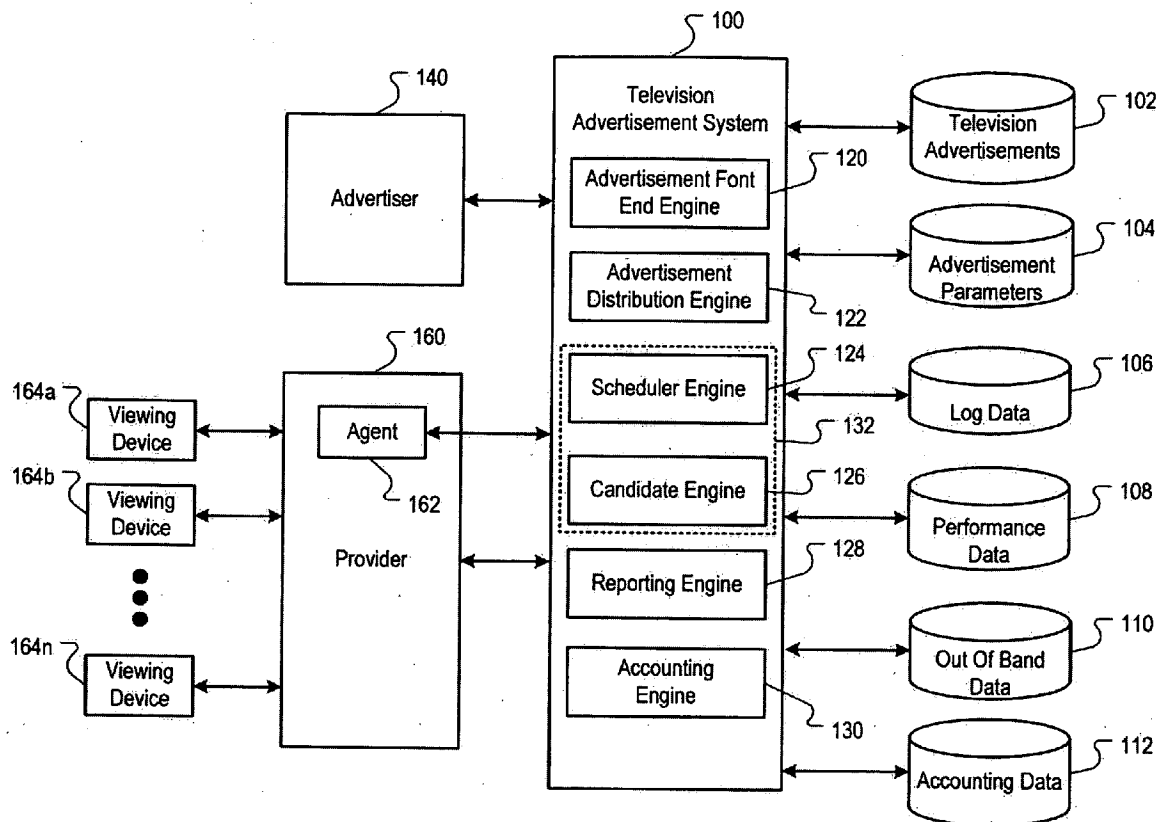

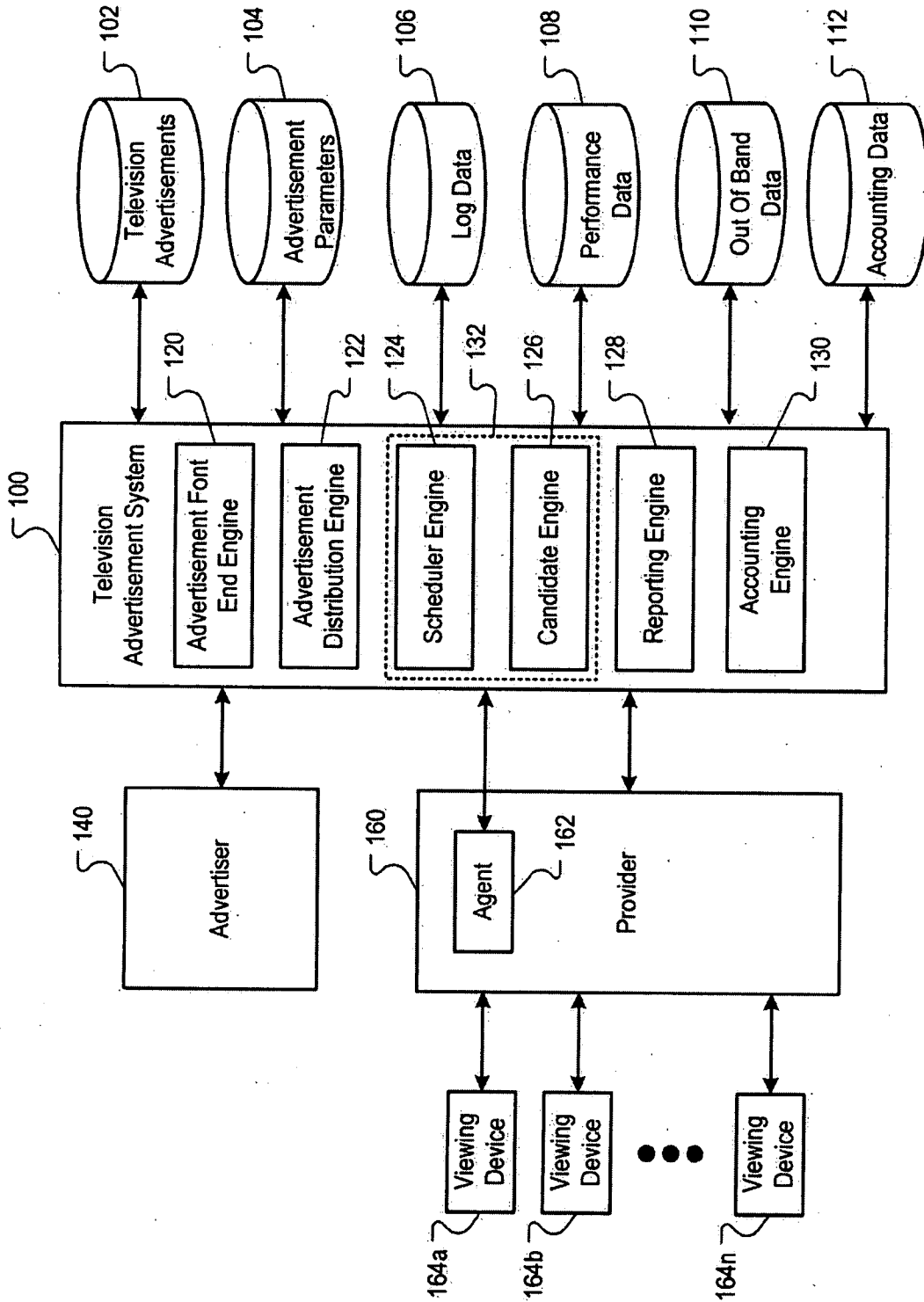

FIG. 1

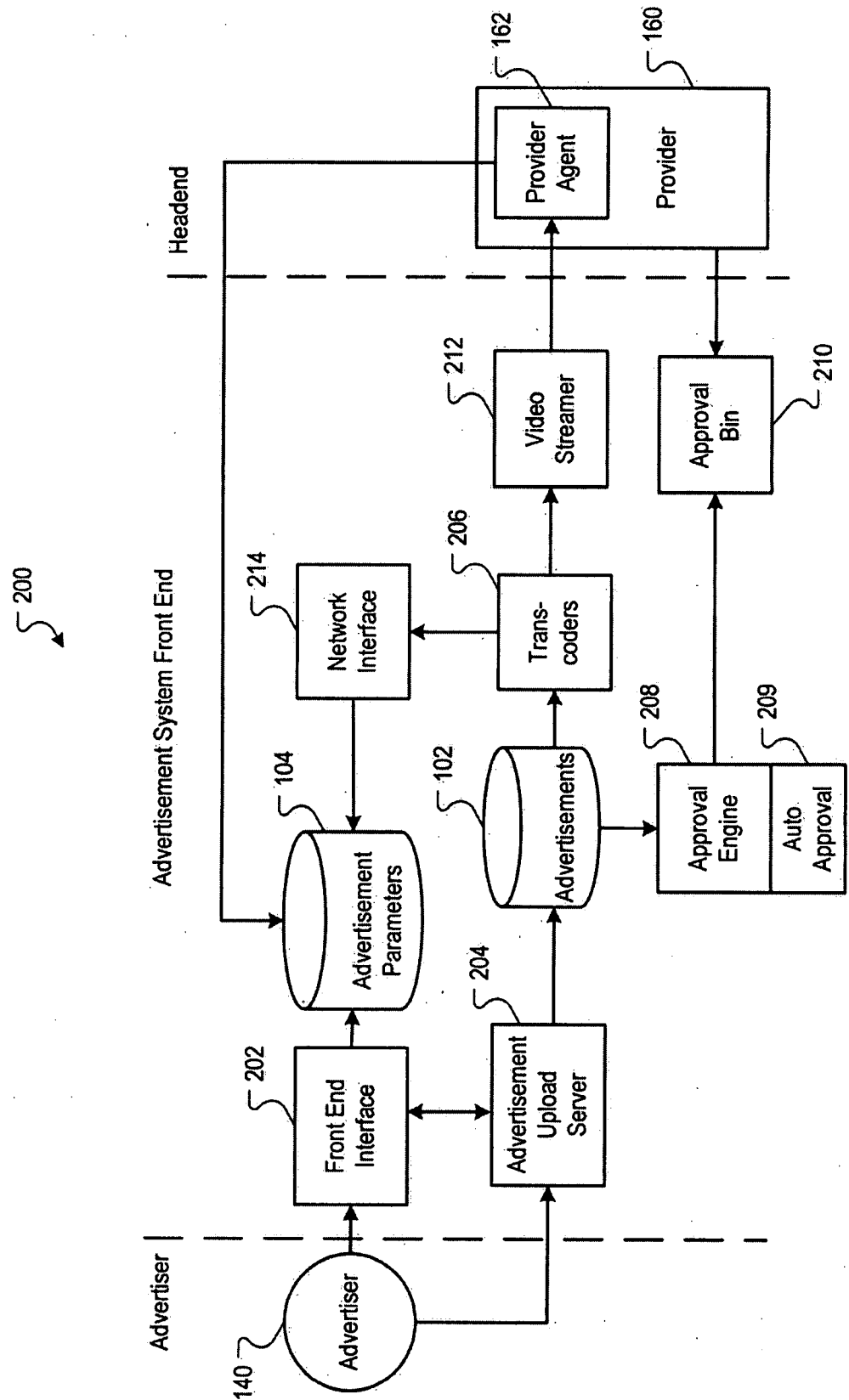

FIG. 2

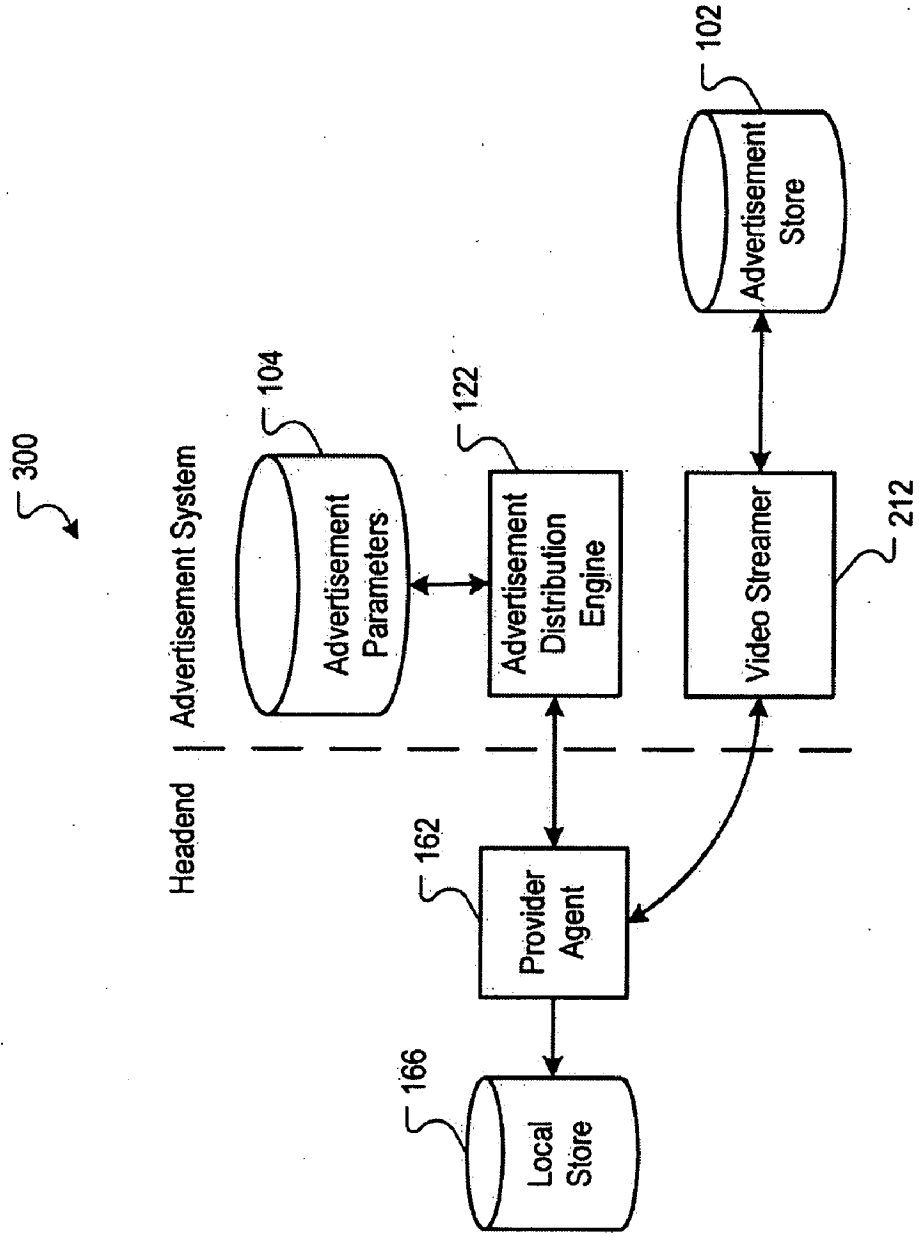

FIG. 3

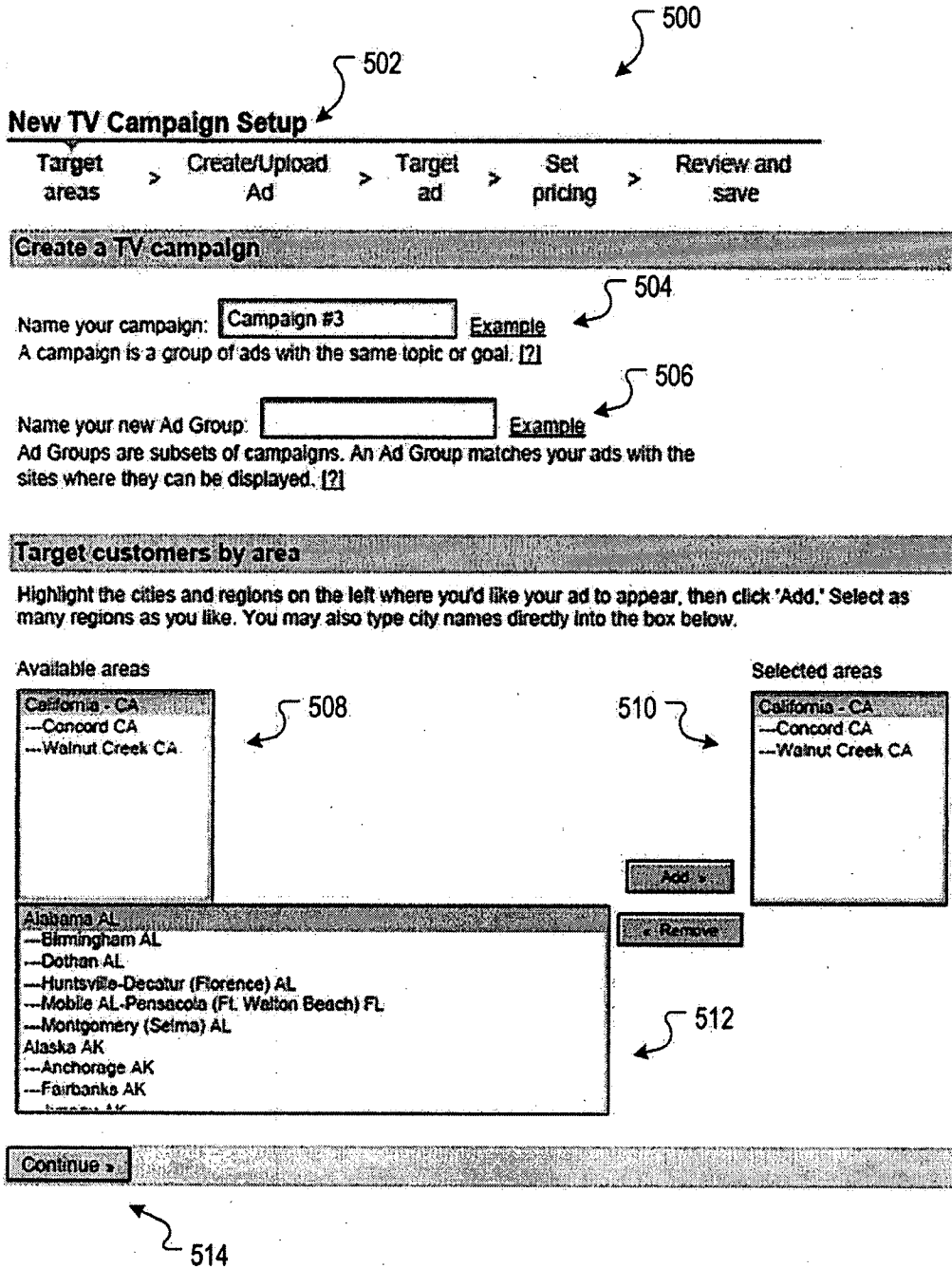

FIG. 5

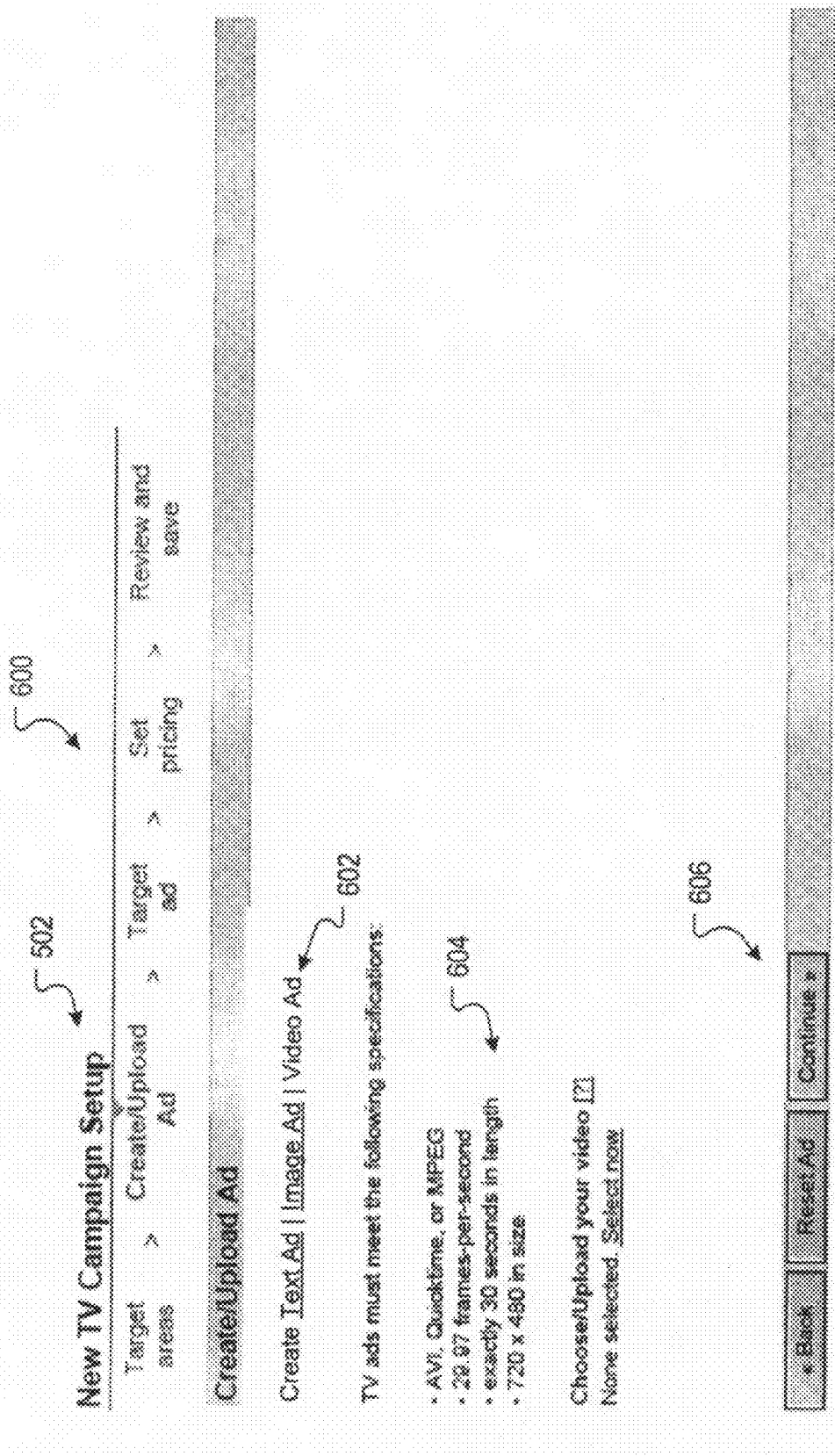

FIG. 6

700

New TV Campaign Setup

Target areas > Create/Upload ad > Target ad > Set pricing > Review and save

Target your ad. Choose networks and times

24 Station 1

37 Station 2

43 Broadcaster A

48 Broadcaster B

51 Broadcaster C

58 Network 21

704 **Choose times** 708

Monday Editing... 706

	Midnight	4am	8am	Noon	4pm	8pm
	✓✓✓✓	✓✓✓✓	✓✓✓✓	✓✓✓✓	✓✓✓✓	✓✓✓✓

Pause on Monday

Run ads: 12:00 am (Midnight) to 12:00 am (Midnight)

+Add another time period

Tuesday Running all hours Edit: ✓✓✓✓ ✓✓✓✓ ✓✓✓✓ ✓✓✓✓ ✓✓✓✓ ✓✓✓✓

Wednesday Running all hours Edit: ✓✓✓✓ ✓✓✓✓ ✓✓✓✓ ✓✓✓✓ ✓✓✓✓ ✓✓✓✓

Thursday Running all hours Edit: ✓✓✓✓ ✓✓✓✓ ✓✓✓✓ ✓✓✓✓ ✓✓✓✓ ✓✓✓✓

Friday Running all hours Edit: ✓✓✓✓ ✓✓✓✓ ✓✓✓✓ ✓✓✓✓ ✓✓✓✓ ✓✓✓✓

Saturday Running all hours Edit: ✓✓✓✓ ✓✓✓✓ ✓✓✓✓ ✓✓✓✓ ✓✓✓✓ ✓✓✓✓

Sunday Running all hours Edit: ✓✓✓✓ ✓✓✓✓ ✓✓✓✓ ✓✓✓✓ ✓✓✓✓ ✓✓✓✓

Midnight 4am 8am Noon 4pm 8pm

 - Running - Paused

710

712

FIG. 7

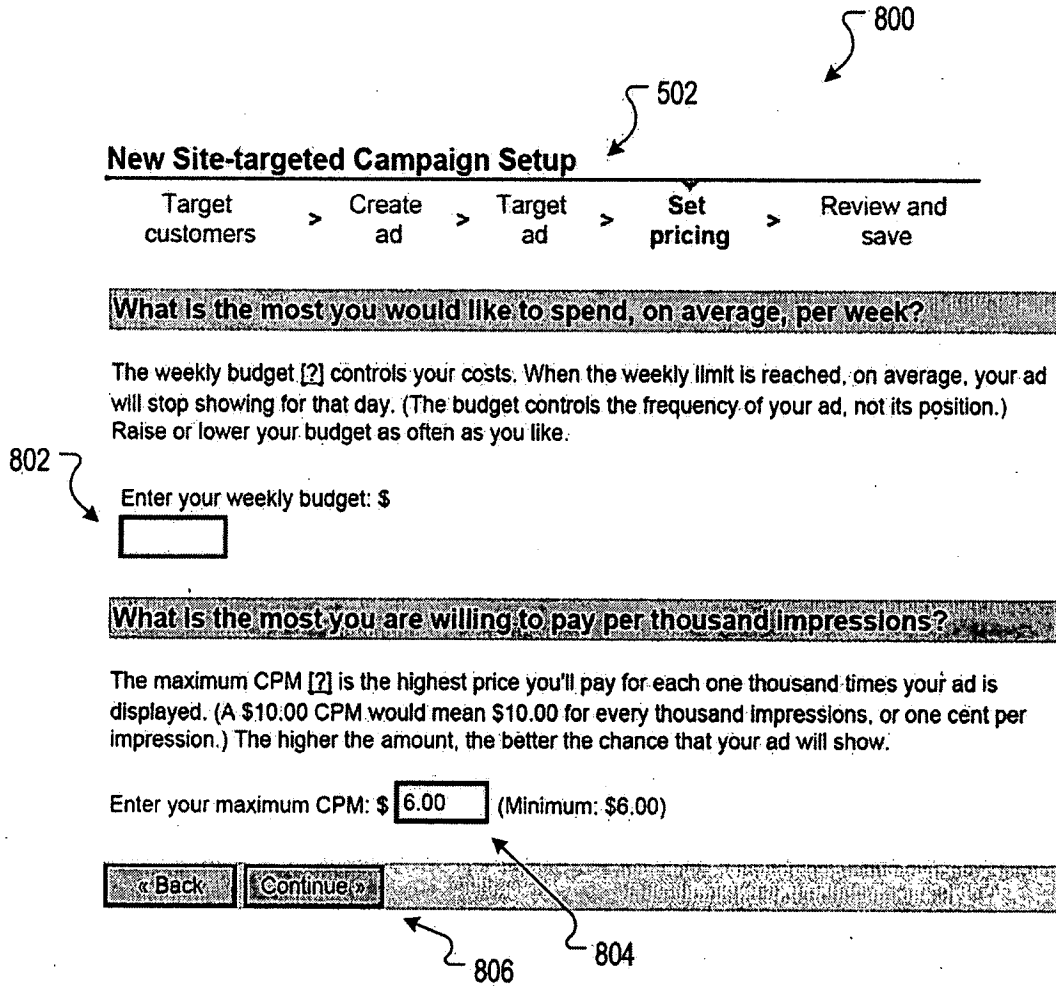

FIG. 8

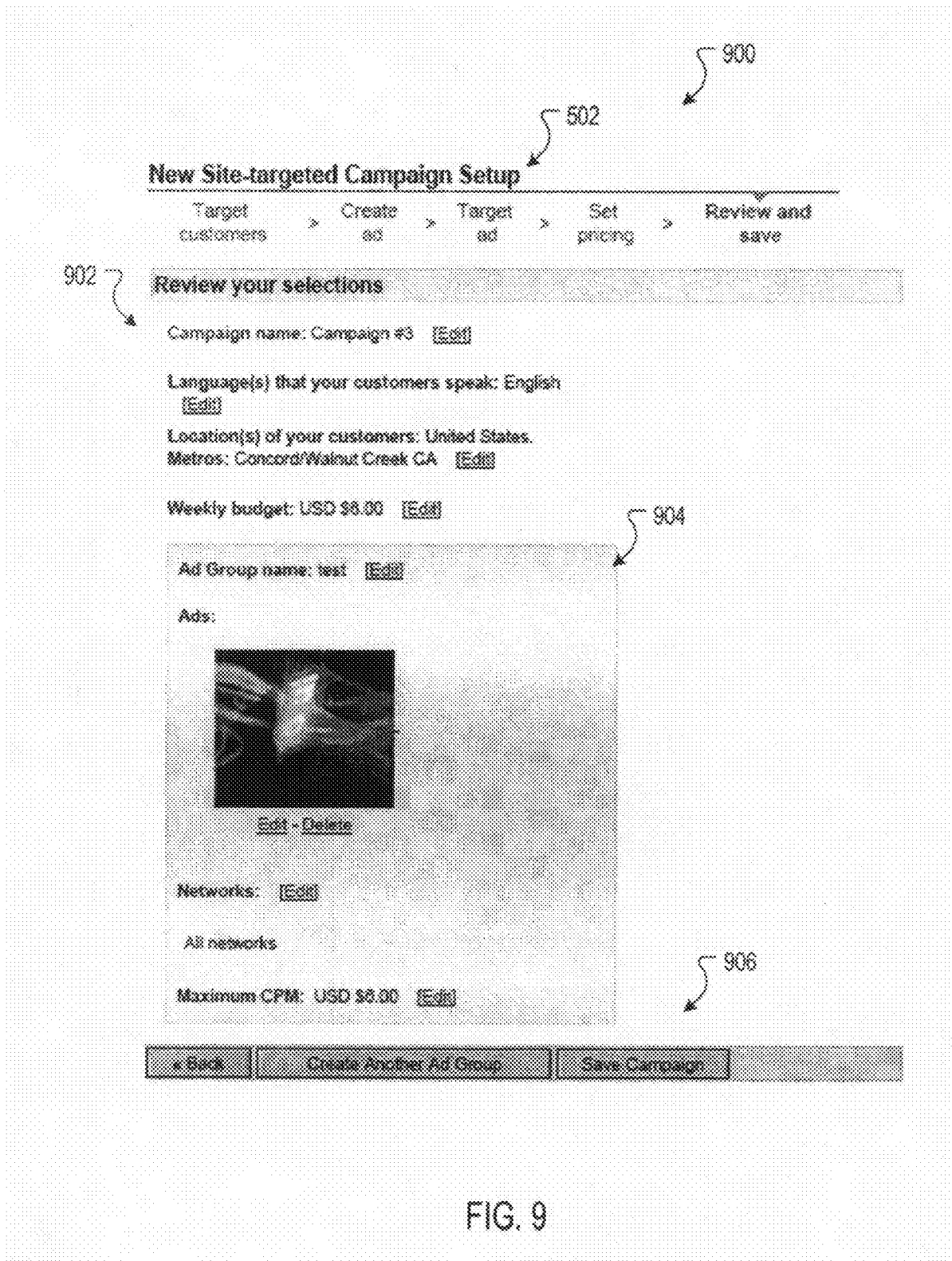

FIG. 9

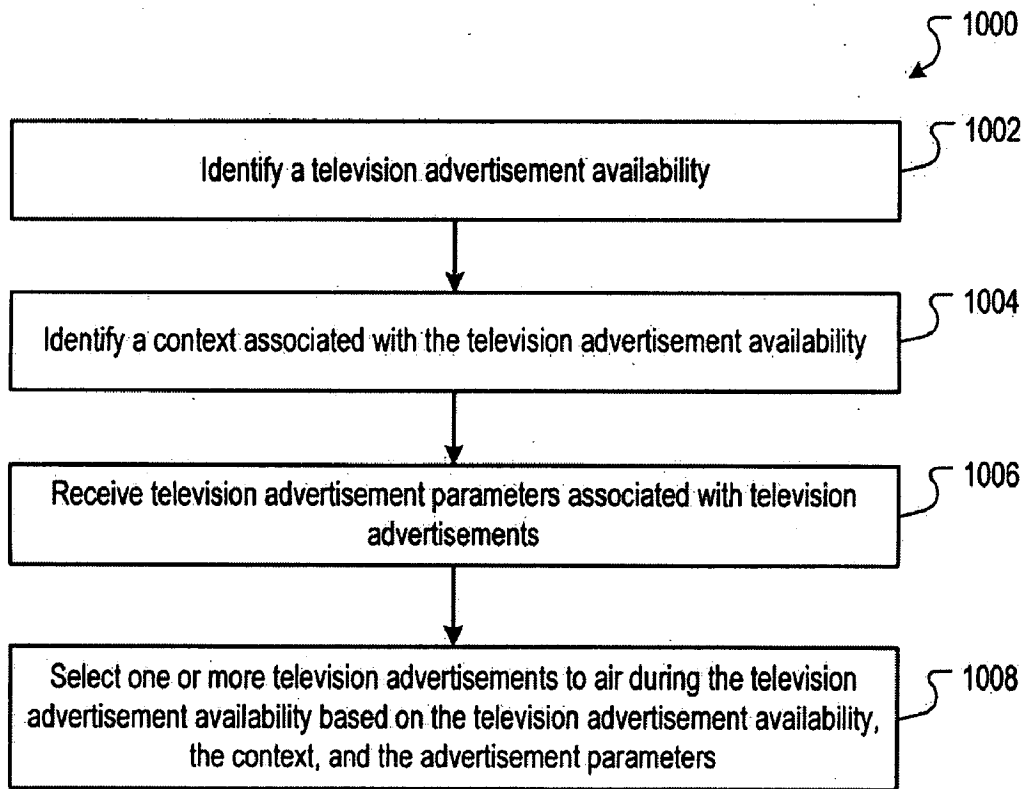

FIG. 10

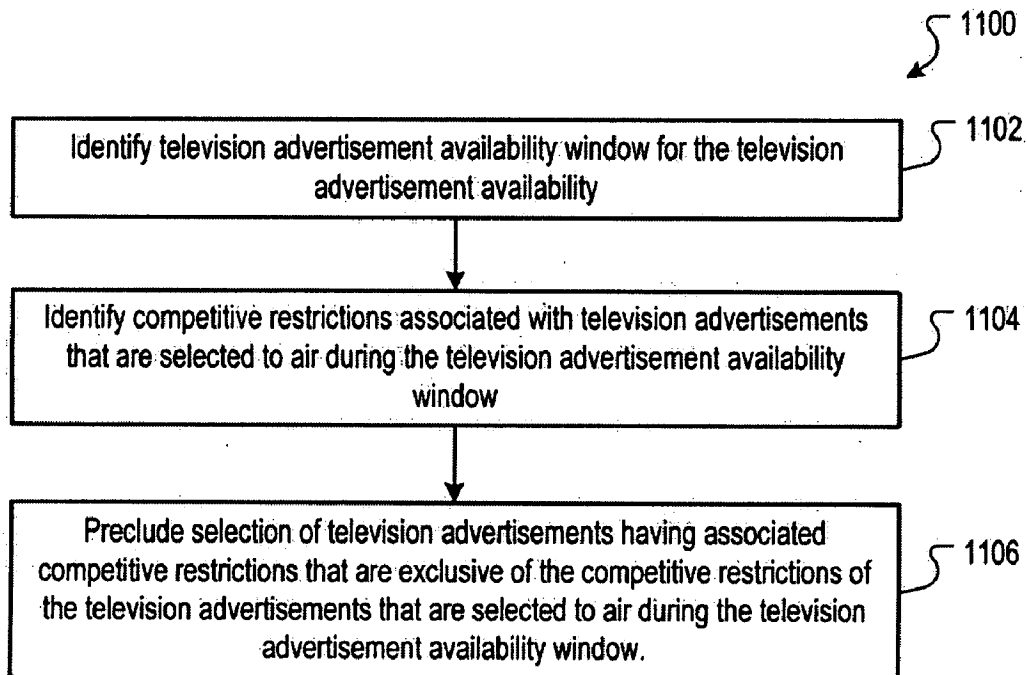

FIG. 11

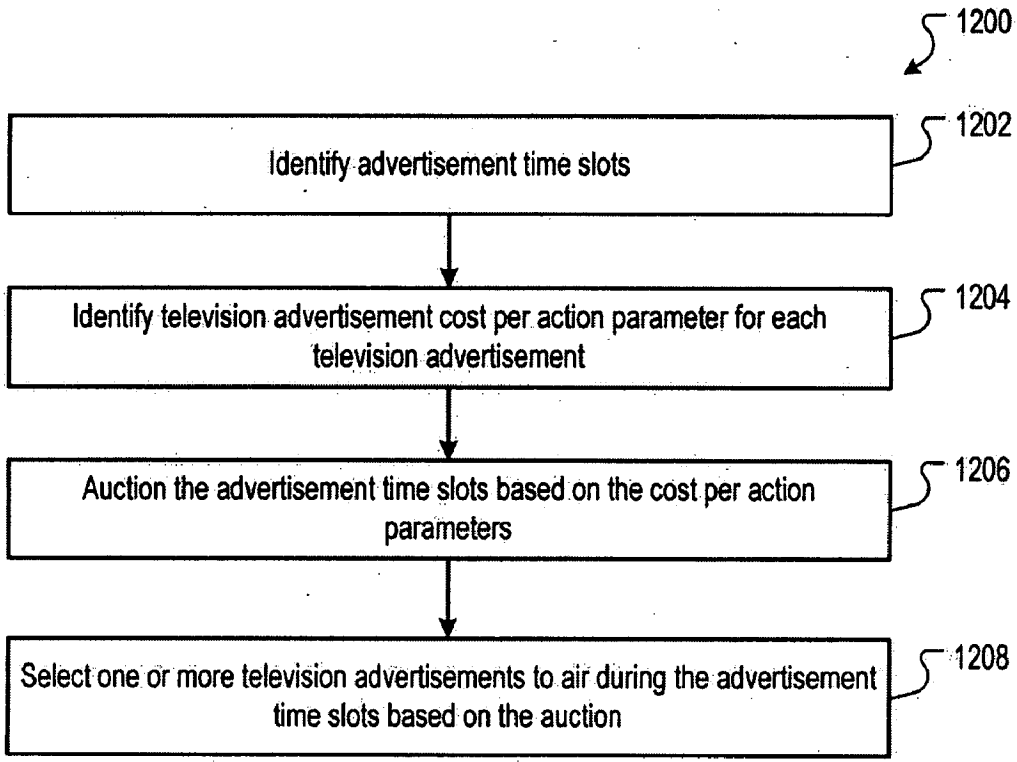

FIG. 12

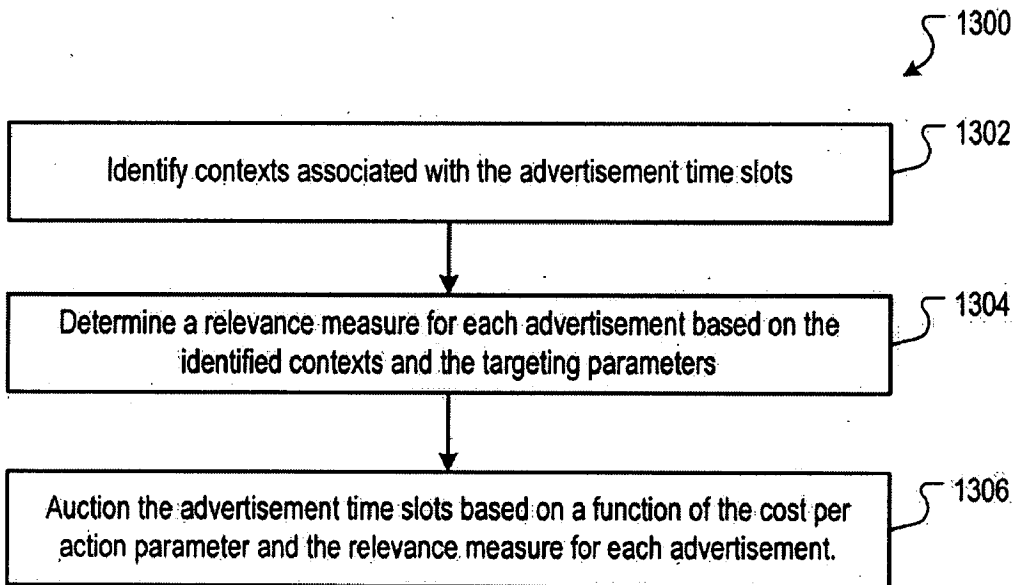

FIG. 13

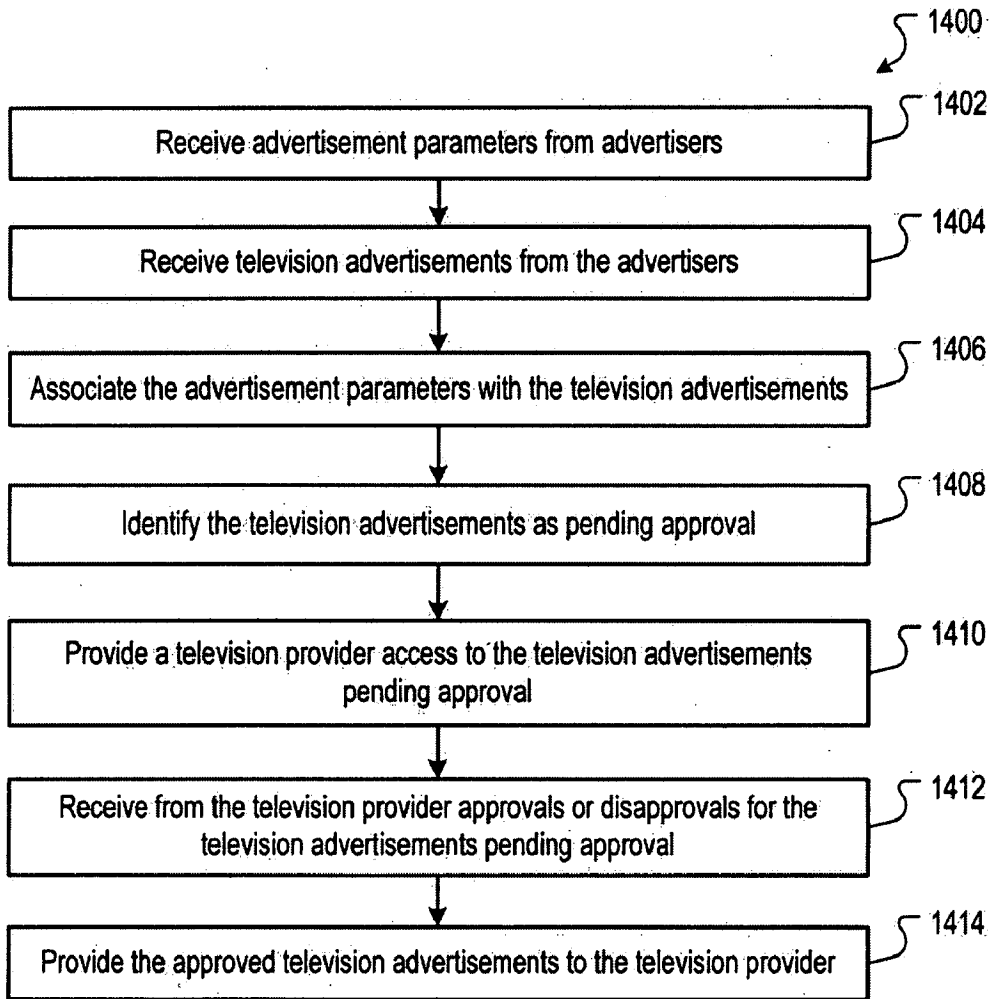

FIG. 14

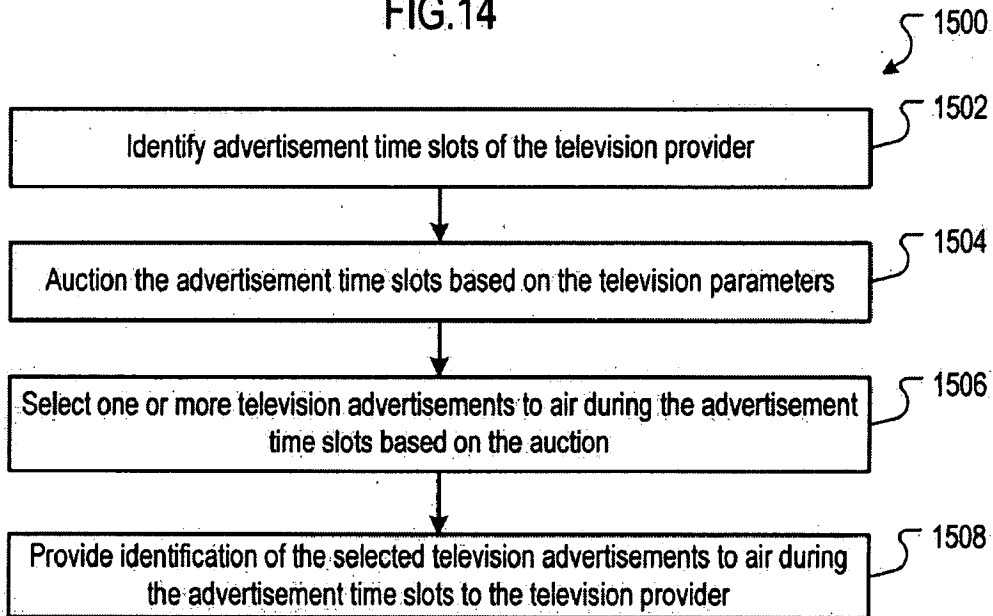

FIG. 15

TELEVISION ADVERTISING

[0001] This application claims the benefit of U.S. Application Ser. No. 60/909,893, filed Apr. 3, 2007, the disclosure of which is incorporated herein by reference.

BACKGROUND

[0002] This disclosure relates to media advertising.

[0003] An advertiser, such as a business entity, can purchase airtime during a television broadcast to air television advertisements. Example television advertisements include commercials that are aired during a program break, transparent overlays that are aired during a program, and text banners that are aired during a program.

[0004] The cost of the airtime purchased by the advertiser varies according to both the amount of time purchased and other parameters such as the audience size and audience composition expected to be watching during the purchased airtime or closely related to the purchased airtime. The audience size and audience composition, for example, can be measured by a ratings system. Data for television ratings can, for example, be collected by viewer surveys in which viewers provide a diary of viewing habits; or by set meters that automatically collect viewing habit data and transmit the data over a wired or wireless connection, e.g., a phone line or cable line; or by digital video recorder service logs, for example. Such rating systems, however, may be inaccurate for niche programming, and typically provide only an estimate of the actual audience numbers and audience composition.

[0005] Based on the ratings estimate, airtime is offered to advertisers for a fee. Typically the advertiser must purchase the airtime well in advance of the airtime. Additionally, the advertiser and/or the television provider may not realize the true value of the airtime purchased if the ratings estimate is inaccurate, or if the commercial that is aired is not relevant in the context of the television program and/or audience.

SUMMARY

[0006] Described herein are systems and methods for television advertising. In one implementation, a television advertisement availability is identified, and a context associated with the television advertisement availability is also identified. Television advertisement parameters associated with television advertisements are received, and one or more television advertisements are selected to air during the television advertisement availability. The selection can be based on the television advertisement availability, the context, and the advertisement parameters.

[0007] In another implementation, advertisement spots, e.g., time slots, are identified, and television advertisement parameters associated with television advertisements are also identified. The television advertisement parameters can include a cost per action parameter for each television advertisement. The advertisement spots are auctioned based on the cost per action parameters, and one or more television advertisements are selected to air during the advertisement spots based on the auction.

[0008] In another implementation, a system includes a television advertisement scheduling device configured to receive a television advertisement request defining a television advertisement availability from a television provider, and to issue a request for candidate television advertisement data based on

the television advertisement request. The television advertisement scheduling device can receive candidate television advertisement data in response to the request for candidate television advertisement data, and select one or more television advertisements to air during the television advertisement availability. The selection can be based on the television advertisement request and the candidate television advertisement data.

[0009] Particular implementations of the subject matter described in this specification can be implemented to realize one or more of the following advantages. Relevant and effective advertisements for millions of television provider subscribers can be delivered locally and/or nationwide by an automated process. The relevant advertisements can more effectively monetize airtime, which can attract additional advertisers and create greater value for the television provider's television advertisement inventory. Additionally, by measuring access of programmer inventory through subscriber viewing devices, such as set top boxes, operators can more effectively monetize specialty channels that serve smaller audiences and for which audience data have been historically difficult to measure.

[0010] Additionally, the television advertising system can, for example, create efficiencies in the buying/selling process through an automated online marketplace. For example, in one implementation, the advertising process is automated from planning the campaign, uploading the advertisement and serving the advertisement. An auction model can create pricing efficiencies for both buyers and sellers of television advertising. Advertisers can benefit from efficiencies by paying only for delivered impressions, or delivered actions, or other types of measurable events. Advertisers can also benefit from receiving the information the advertisers need to continually enhance the effectiveness of the advertiser's advertisements. The system can be implemented organically or can be implemented with third-party infrastructure partners.

[0011] Additional details of one or more implementations of the subject matter described in this specification are set forth in the accompanying drawings and the description below. Other features, aspects, and advantages of the subject matter will become apparent from the description, the drawings, and the claims.

BRIEF DESCRIPTION OF THE DRAWINGS

[0012] FIG. 1 is a block diagram of an example television advertisement system.

[0013] FIG. 2 is a block diagram of an example television advertisement front end system.

[0014] FIG. 3 is a block diagram of an example television advertisement distribution system.

[0015] FIG. 4 is a block diagram of an example television advertisement scheduling and reporting system.

[0016] FIGS. 5-9 are example television advertisement front end environments.

[0017] FIG. 10 is a flow diagram of an example process of selecting television advertisements for advertisement availability.

[0018] FIG. 11 is a flow diagram of an example process for restricting television advertisements.

[0019] FIG. 12 is a flow diagram of an example process for auctioning advertisement spots for television advertisements.

[0020] FIG. 13 is a flow diagram of an example process for auctioning advertisement spots based on a cost parameter and a quality parameter.

[0021] FIG. 14 is a flow diagram of an example process for receiving and distributing advertisements from advertisers.

[0022] FIG. 15 is a flow diagram of an example process for providing auction results to a television provider.

[0023] Like reference numbers and designations in the various drawings indicate like elements.

DETAILED DESCRIPTION

[0024] FIG. 1 is a block diagram of an example television advertising system 100. The television advertising system 100 can, for example, deliver relevant content (e.g., advertisements) to viewers to facilitate operator monetization of programming and quantification of advertisement delivery to target markets. The television advertising system 100 can, for example, be implemented on one or more computer servers, and can provide and receive data over a network. Example networks include local area networks (LANs), wide area networks (WANs), telephonic networks, and wireless networks (e.g., 802.11x compliant networks, satellite networks, cellular networks, etc.). Additionally, the television advertising system 100 can, for example, communicate over several different types of networks, e.g., the Internet, a satellite network, and a telephonic network.

[0025] In general, the television advertising system 100 can receive television advertisements and advertisement campaign data from an advertiser 140, e.g., an entity that provides television advertisements, such as a commercial entity that sells products or services, an advertising agency, or a person. The television advertising system 100 can facilitate the provisioning of television advertisements to a television provider 180, e.g., an entity that facilitates the delivery of a television broadcast to viewers, such as cable provider, a digital satellite provider, a streaming media provider, or some other media provider. The provider 180 can, for example, receive a provider agent 182 from the television advertising system 100. The provider agent 182 can, for example, be located at an advertising broadcast insertion location of the provider 182, e.g., at a head end of the provider.

[0026] The provider agent 182 can, for example, receive advertisement availability schedules from the provider 180 and provide the advertisement availability schedules to the television advertising system 100. For example, the provider agent 162 can read schedule requests, either in real time or ahead of time, and identify which schedule times the television advertising system 100 has permission to fill with advertisements provided by the television advertising system 100. Alternatively, the provider agent 182 can determine if one or more advertisements already scheduled or should/can be preempted or receive information that a scheduled advertisement should be preempted in accordance with one or more criteria (e.g., to improve revenue generation for the provider, or if an advertiser's budget has been depleted after a related advertisement was scheduled, etc.). The provider agent 182 can request the television advertising system 100 to identify a relevant advertisement for an identified airtime advertisement spot, e.g., an open advertisement slot or a preempted advertisement slot.

[0027] The advertisement can be deemed relevant based on advertisement meta data and an advertisement context, e.g., an advertisement for extreme sporting equipment for an advertisement having an available advertising budget may be

selected for airing during a televised sporting event for which the meta data identifies as a primary demographic 18-30 year old males.

[0028] The television advertising system 100 can, for example, select candidate advertisements to air during an advertisement availability based on account advertiser bids, budgets, and any quality metrics that have been collected, e.g., conversions, viewer actions, impressions, etc. For example, advertisements can be selected to air during the advertisement availability according to a computer-implemented auction. One exempting auction is a Vickrey-style in which each advertiser pays the bid of the next highest advertisement. Other auction processes can also be used, e.g., setting an advertiser bid equal to the estimated number of viewer impressions multiplied by the price an advertiser has offered to pay for each impression, etc.

[0029] Different bidding types can be implemented in the computer-implemented auction. For example, the bidding types can be cost per airing, a cost per impression, a cost per full viewing of the advertisement, a cost per partial viewing of the advertisement, etc. Other types of costs per actions can also be used, such as a phone call resulting from phone call solicitations; a cost per network airing (e.g., \$5.00 per 1000 impressions on a first network, \$6.00 per 1000 impressions on a second network), cost per action scaled by the time of day, etc. An auction process can, for example, support ads with different or even multiple (hybrid) bidding types.

[0030] The advertisements selected from the television advertising system 100 auction, the advertisement air time, and/or the advertisement can be provided to the provider 180. For example, all available advertisements, or a subset thereof, can be provided to the provider 180 prior to airing, and the provider agent 182 need only receive an advertisement identifier indicating which advertisement is to air during particular advertisement air time.

[0031] The provider agent 162 can thereafter provide a status to the television advertising system 100 regarding when the advertisement aired. The provider agent 182 can also, for example, provide anonymized impression data related to viewing devices 164a-184n. For example, logs related to viewing device 164 activity, e.g., set top box logs, can be anonymized to remove personal information related to viewing activities and provided to the television advertising system 100. In another implementation, such information can be provided by the provider 160, or by a third party.

[0032] In one implementation, based on the impression data for the airing of the advertisement, the television advertising system 100 can charge an advertiser a fee for airing the advertisement. The fee can, for example, be substantially in proportion to the number of impressions determined for a particular airing of an advertisement.

[0033] In one implementation, the fee can, for example, be based on the bidding type. For example, the bid may be based on a cost per airing, and thus an advertiser would be charged a fee for the airing of the advertisement. Other fee determinations can also be used.

[0034] The impressions can, for example, be measured statistically. An impression can be a household impression, e.g., the airing of an advertisement in household and independent of the number of televisions in a household. If the advertisement is aired on a viewing device in the household, one household impression can be recorded. Other impression types can also be used. For example, impressions can be generated by a program rating percentage, e.g., a percentage

of viewership in measurable households; or by a program share percentage, e.g., a percentage of viewership in active measured homes; or by some other statistical measurement.

[0035] By way of another example, impressions can be measured by an analysis of activity logs of the viewing devices **164**. For example, a household may have three viewing devices **164**, and at a given time two of the devices may be tuned to a first channel and the third device may be tuned to a second channel. If a first commercial airs on the first channel and a second commercial airs on the second channel, impressions can be generated for each viewing device.

[0036] An impression can be dependant on a channel tune status when an advertisement airs on a channel. For example, an impression can occur when a viewing device **164** is tuned to a broadcast stream in which an advertisement is inserted, and the viewing device **164** remains tuned to the broadcast stream for N consecutive seconds during the actual display time of the insertion. For example, an impression can be defined as a viewing device remaining tuned to a broadcast stream for five seconds after the advertisement begins to air. Alternatively, an impression can be defined as a viewing device tuned to a broadcast stream when an advertisement is airing and remaining tuned to the broadcast stream for five seconds after tuning to the broadcast stream. Other tune times can also be used.

[0037] Likewise, other impression types can also be used. For example, an impression can be based on an advertisement exposure, e.g., a brief exposure of an advertisement, or a full viewing of the advertisement, of a threshold viewing in between, e.g., five seconds, or five seconds of the first fifteen seconds; or a percentage of the advertisement viewed, etc.

[0038] In an implementation, the television advertisement system **100** can also include one or more data stores to store television advertisements and associated data, e.g., meta data related to the television advertisements, performance data related to the television advertisements, accounting data related to the advertisers and television advertisements, etc. In one implementation, the television advertising system **100** includes an advertisement data store **102**, an advertisement parameter store **104**, a log data store **106**, a performance data store **108**, and an out of band data store **110**. Additional advertisement related data can also be stored, e.g., an accounting data store **112** can store accounting data.

[0039] The television advertisement data store **102** can, for example, include advertisements that can be broadcast or aired during an advertisement spot. Example television advertisements include video advertisements, banner advertisements, overlay advertisements, such as logos, URLs, dynamic pricing information for an advertisement, etc., and other advertisements that can be used to convey information visually and/or aurally during a television broadcast.

[0040] The television advertisement parameter data store **104** can, for example, include cost per action parameters, frequency values, competitive restrictions, advertising budget data, geographic data, targeting data, etc. The television advertisement parameters **104** can, for example, be specified by the advertiser **140**, and/or can be automatically updated based on the performance of advertisements during an advertisement campaign.

[0041] The log data store **106** can include data logs from viewing devices **164**, e.g., set top boxes, satellite receivers, etc. The log data can include reporting data that identifies channel tunes, e.g., a channel identifier to which the viewing device was tuned, and channel tune times, e.g., the times that

the viewing device was tuned to a channel. Other data can also be included, e.g., key presses of remote devices associated with the viewing devices **164**, commands received by the viewing devices **164**, etc. For example, if the viewing device **164** is a digital video recorder, the log data can include a list of recorded programs, and for each recorded program a record that indicates whether the recorded program has been played back, and the actions taken during playback, such as fast forwarding or skipping commercials can be included.

[0042] The performance data store **108** can, for example, include quality data, e.g., a total number of impressions for each advertisement, or an impression rate for each advertisement, and/or other quality parameter and/or impression parameters. Example impression rates include a percentage of total potential viewers, e.g., the number of identified impressions divided by the number of subscribers; a percentage of actual impressions of a total number of impressions, e.g., a percentage of reliable impressions divided by a total number of impressions. An example reliable impression is an impression that satisfies a rule set or condition that determines that the impression was likely viewed on a viewing device by one or more persons.

[0043] Other performance data can also be stored in the performance data store **108**, e.g., performance of a particular advertisement during particular programming, the probability that viewers will tune to another channel during an advertisement; the probability that viewers will fast-forward through the advertisement; etc. Such probabilities can be normalized to average behavior on a per-advertisement basis, or on a per-time slot basis, or on some other measurable basis.

[0044] Performance data can also include data related to how much of an advertisement a viewer watched when the advertisement aired. For example, statistics related to aggregate tune-in and tune-out times; number of viewers, etc. can be measured and evaluated to determine quality data related to advertisements based on viewing percentages.

[0045] The out of band data store **100** can, for example, include data related to the relevance or popularity of particular advertisements, advertisement subject matter, and television programs. For example, web pages can be mined to determine whether particular television programs are expected to have increased viewership, e.g., a sudden increase in fan pages for a program can be correlated to an increase in an expected ratings value, and the resulting data can be stored in the out of band data store **110**. Other data can include data related to search queries, page views on an advertise site, etc.

[0046] Likewise, the out of band data store **110** can, for example, store data resulting from mining a video web site to identify television advertisements that are particularly popular, e.g., a video web site may record viewing statistics that indicate a particularly humorous advertisement is relatively popular among a certain demographic. Such data can be used to further refine the advertising selection process.

[0047] Additionally, when sites related to television programs can be mined to determine relevance of products or services related to the television program. For example, a particular program may reference a product in an episode, and the mining of fan sites related to the program may reveal that the product mention has generated a significant interest in the product and related products. Accordingly, advertisements related to the product and related products may be deemed more relevant for time slots during the program.

[0048] The accounting data store **112** can, for example, store accounting data related to advertisements and advertis-

ers 140. The accounting data store 112 can store such data as campaign budgets, monthly spend parameters, and account balances for advertisers.

[0049] Other data can also be stored, such as data that can be utilized to adjust viewing forecasts, adjust pricing models, adjust relevancy measures, etc. For example, performance data related to certain products or services advertised, e.g., anonymized historical campaign data, trend analysis of program viewership, e.g., viewing statistics of program series episodes in first run, repeat, and syndication, etc. can be stored for analysis. In one implementation, data related to advertisements that were aired during time slots not served by the advertisement system 100 can be stored to analyze other advertising market models, e.g., fixed priced advertising markets, reserved advertising markets, etc.

[0050] The advertisement data store 102, advertisement parameter store 104, log data store 108, performance data store 108, the out of band data store 110 and the accounting data store 112 can be implemented separately or in combination. For example, in one implementation, the advertisement data store 102, advertisement parameter store 104 and performance data store 108 can be implemented in a single advertisement database. Other combinations and/or subcombinations can also be used.

[0051] The television advertisement system 100 can include an advertisement front end engine 120, an advertisement distribution engine 122, a scheduler engine 124, a candidate engine 126, a reporting engine 128, and an accounting engine 130. The advertisement front end engine 120, advertisement distribution engine 122, scheduler engine 124, candidate engine 126, reporting engine 128, and accounting engine 130 can, for example, be distributed among a plurality of computer devices, e.g. server computers communicating over a network, or can be implemented on a single computer, e.g., as multiple threads on a server computer. Other implementation architectures can also be used. The advertisement front end engine 120, advertisement distribution engine 122, scheduler engine 124, candidate engine 126, reporting engine 128, and accounting engine 130 can, for example, be implemented in software, such as executable object code, interpreted script instructions, or in combinations of executable and interpreted instructions. Other software and/or hardware implementations can also be used.

[0052] The advertisement front end engine 120 can, for example, be configured to receive advertisement data and television advertisements from the advertiser 140 and associate the advertisement data with the television advertisements. In one implementation, the advertisement front end engine 140 can include a web-based interface through which the advertiser 140 can upload television advertisements and associated campaign data, e.g., advertising budgets, targeting data, such as demographics and air times, product and/or service description data, such as vertical classifications, price ranges, subject matter, etc.

[0053] In one implementation, the advertisement front end engine 120 can include an approval engine configured to identify a television advertisement pending approval by the television provider 180. Utilizing the approval engine 180, the publisher may optionally review an advertisement and either approve or disapprove of the advertisement. For example, a cable provider may disapprove of advertisements that are of particularly low quality, e.g., poor sound quality, incorrect advertisement data, etc.

[0054] The advertisement distribution engine 122 can, for example, be configured to provide approved advertisements to the television provider 160. In one implementation, the advertisements are provided to the television provider 160 in advance of airing the advertisements. The provider agent 162 can periodically issue a request to the television advertising system 100 for any new advertisements to be downloaded. For any such advertisements, the provider agent 162 or the distribution engine 122 can initiate the download, and upon successful completion the provider agent 162 can notify the television advertising system 100 of a successful download. The television advertising system 100 can, for example, label the download with a particular ID that i can be later user during scheduling to identify the scheduled advertisement. Accordingly, the publisher 180 can receive an advertisement identifier associated with an advertisement availability, e.g., a time slot, and can retrieve the advertisement locally at the television provider 180 premises and insert the selected advertisement into the broadcast stream.

[0055] The television advertisement scheduler engine 124 can, for example, be configured to receive a television advertisement request defining a television advertisement availability from the television provider 160, and issue a request for candidate television advertisement data, e.g., data related to advertisements that are candidates for being selected to fill the advertisement availability. The television advertisement request can include geographic data, provider identification, network data, program data, and other data. For example, a request can specify advertisements that can be shown in the geographic are of the USA/California/Bay Area/Mountain View, with a remoteRepositoryId of XX of a television provider, for a television provider YY, on a television network ZZ, to be scheduled within the time window of Monday 2:00 PM-3:00 PM, and at a preferred time of 2:16 PM.

[0056] The candidate engine 126 can, for example, be configured to identify candidate television advertisement data in response to the request for candidate television advertisement data. The identification can be based on data associated with the television advertisements, such as the data stored in the advertisement parameter data store 104. The candidate engine 126 can implement various targeting and/or filtering rules. For example, a budget restriction can be imposed if an advertiser budget is nearly depleted, and the expected fee for airing the advertisement based on expected impressions would exceed the remaining advertising budget.

[0057] Other example rules include the advertisement being successfully downloaded to the television provider 160; the advertisement targeting the location or a superset of the location where the advertisement will be showing; the advertiser 140 or advertisement must not be considered fraudulent or delinquent; the publisher 160 has approved the advertisement for showing; the advertisement is targeting this particular television network and/or time; the advertisement is targeting a television program which, through internal or third party data sources, corresponds to the given request; and the advertisement is targeting a demographic profile which, through internal or third party data sources, corresponds to the given request. Fewer or more filtering and targeting conditions can also be applied.

[0058] In response to receiving the candidate advertisement data, the television advertisement scheduler engine 124 can select one or more television advertisements to air during the television advertisement availability. The selection can be based on the television advertisement request and the candi-

date television advertisement data. For example, the television advertisement request can be utilized to determine a context, e.g., the context of the programming associated with the advertisement, such as sporting event, an entertainment genre, a news program, etc.; or the context of the television network, e.g., a network type; or the context of a television channel; or the context of the time of day; or a combination of any of such examples. The context can be utilized to determine a relevancy score, and the relevancy score can be utilized to scale an auction result so that bids related to advertisements that are more relevant to the identified context are scaled higher than bids related to less relevant advertisements.

[0059] In an implementation, the scheduler engine 124 and/or the candidate engine 126 can enforce advertisement restrictions. For example, the scheduler engine 124 and/or the candidate engine 126 can filter the advertisements to eliminate unwanted advertisements, e.g., frequency capping can be performed to limit the scheduling of certain advertisements based on an amount of time since the advertisement was last aired; competitive restrictions can be applied so that one advertisement cannot be placed near another advertisement of a competitor, etc.

[0060] The reporting engine 128 can, for example, receive television advertisement report data from the provider 160 and determine whether the selected television advertisement aired based on the television advertisement report data. For example, an advertisement may not air due to a programming irregularity, e.g., a sporting event going beyond a scheduled broadcast, an interruption to scheduled programming due to breaking news, etc. in an implementation, the reporting engine 128 can process reporting logs, e.g., set top box logs, from viewing devices 164 to determine advertisement impressions.

[0061] The accounting engine 130 can, for example, receive the impression data from the reporting engine 128 and generate accounting data for advertisers. In one implementation, the accounting data can detail fees owed to the television advertising system 100. The fees can, for example, be based on a cost per action parameter associated with an advertisement. For example, if an advertiser has specified \$10,00 as a maximum cost per thousand impressions for a television commercial, and the reporting data indicates that 420,000 reliable impressions were generated from airing the advertisement then the advertiser may be billed for \$4,200.

[0062] In another implementation, the accounting data can detail fees owed to the television advertising system 100 and the publisher pursuant to a revenue sharing agreement. An example revenue sharing agreement can include a percentage split between the operator of the television advertisement system 100 and the television provider 160. For example, the operator of the television advertising system may receive 20% of the fee, and the operator of the publisher 160 may receive the remaining 80% of the fee. Another example revenue sharing agreement can include a first fee up to a maximum cap going to the operator of the television advertisement system, and the remaining fee going to the operator of the television provider 160. For example, the operator of the television advertising system may receive the first \$500 of the fee, and the operator of the publisher 160 may receive the remainder of the fee. Other revenue sharing agreements can also be used.

[0063] The advertisement front end engine 120, advertisement distribution engine 122, scheduler engine 124, candi-

date engine 126, reporting engine 128, and accounting engine 130 can be implemented separately or in combination. For example, in one implementation, the scheduler engine 124 and the candidate engine 126 can be integrated as a single auction engine 132 on a computing device. Other combinations and/or subcombinations can also be used.

[0064] The system 100 of FIG. 1 can also facilitate the serving of other types of advertisement availabilities. For example, in addition to serving advertisement availabilities related to advertisement spots, times slots, and pods, advertisement availabilities that are dynamic, e.g., availabilities that are decided in real time, can also be served. An example dynamic availability can include the canceling of a scheduled advertisement, either at the request of the advertiser or automatically, such as when the advertiser's budget is depleted; or in the event of a programming delay, e.g., a programming delay for a live event, etc.

[0065] FIG. 2 is a block diagram of an example television advertisement front end system 200. The television advertisement front end system 200 can, for example, be implemented in the advertisement system 100 of FIG. 1.

[0066] The advertisement front end system 200 can facilitate the provisioning of advertisement data and television advertisements from the advertiser 140 or an agent of the advertiser, and can facilitate associating the advertisement data with the television advertisements. In one implementation, the advertisement front end system 200 can include a web-based front end interface 202 and an advertisement upload server 204 through which the advertiser 140 can upload television advertisements and associated campaign data associated with the advertisements, e.g., advertising budgets, targeting data, such as demographics and air times, product and/or service description data, such as vertical classifications, price ranges, subject matter, etc. FIGS. 5-9 provide example front end user interface environments.

[0067] In one implementation, the advertisement upload server 204 can receive digital representations of the advertisements, e.g., video files, audio files, and text data files, that define the advertisements, e.g. video advertisements, including commercials, banners, and logo overlays; audio advertisements, and text-based advertisements. In another implementation, the advertisements can be provided to the advertising front end system 200 in either digital or analog form, e.g., video tapes, DVDs, etc. for processing for storage into the advertisement data store 102.

[0068] The advertisements stored in the advertisement data store 102 may require transcoding into one or more different presentation formats. For example, an advertisement may be provided in high definition and in a first aspect ratio; the advertisement may thus be transcoded to conform to another video standard, such as NTSC or PAL. The transcoded advertisements can be accessed by a video streamer 212 and provided to provider 160 for local storage. In one implementation, the provider agent 162 can poll the advertisement front end system 200 periodically, e.g., daily or weekly, to request any new advertisements that have been uploaded and processed by the advertisement front end system 200. Alternatively, the provider agent 162 can request new advertisements after being unable to locate an advertisement locally, or if the provider 160 indicates that an advertisement cannot be located in a local data store.

[0069] In one implementation, newly added advertisements can be designated as pending approval, and an approval engine 208 can be configured to identify television advertise-

ments pending approval by a television provider and store the pending advertisements, or links to the pending advertisements, in an approval bin 210. The approval engine can receive television provider 160 approval data for each television advertisement pending approval and approve or disapprove the television advertisement based on the television provider approval data. Approved advertisements can thereafter be downloaded or otherwise accessed by the provider 160, conversely, disapproved advertisements will not be provided to the provider 160. Accordingly, only approved advertisements will air on broadcast signals generated by the provider 160.

[0070] In one implementation, advertisements awaiting approval can be automatically approved after an expiration of a time period, e.g., 72 hours. In another implementation, advertisements awaiting approval can be automatically disapproved after an expiration of the time period.

[0071] In another implementation, the approval engine can receive front end system 200 approval data for each television advertisement pending approval and approve or disapprove the television advertisement based on the front end system 200 approval data. For example, an operator of the front end system 200 may enforce various policies for advertisements, e.g., quality requirements, subject matter, etc.

[0072] In one implementation, the approval engine 208 can include an automated approval engine 209 that is configured to store approval criteria for each presentation format and evaluate a television advertisement in a presentation format against the corresponding approval criteria. Based on the evaluation, the automated approval engine 209 can automatically approve or disapprove the advertisement. For example, approval criteria based on color balance, sound balance, etc. can be utilized to automatically approve a transcoded advertisement. The automatically approved advertisements or access to the automatically approved advertisements can thereafter be provided to the approval bin 210.

[0073] After the advertisements are downloaded to the provider 160, or after the provider is otherwise provided access to the advertisements so that the advertisements can be aired by the provider, the provider agent 162 can provide an acknowledgement signal to the advertisement front end system 200. The acknowledgement signal can, for example, specify that the publisher has received an advertisement or otherwise has access to the advertisement for airing. The acknowledgement signal can identify the publisher and be stored in the advertisement parameter data store 104 so that each advertisement can be associated with a corresponding list of publishers 160 that can air the advertisement.

[0074] In one implementation, a network interface 214 can be utilized to provide access to the advertisements stored in the advertisement data store 104. For example, the network interface 214 can include a search engine interface and can serve the advertisements over a network, such as the Internet, in response to search queries that are relevant to the advertisement, in an implementation, the advertiser 140 can specify whether an advertisement that can be aired by the publisher can likewise be served over a network through the network interface 214.

[0075] FIG. 3 is a block diagram of an example television advertisement distribution system 300. The advertisement distribution system 300 can, for example, be implemented in the advertisement system 100 of FIG. 1.

[0076] The advertisement distribution system 300 facilitates the storing of advertisements on a local data store, e.g.,

local store 166, associated with the television advertiser 160. The storage of the advertisement at a focal store 166 can, for example, facilitate real-time or near real-time auctioning and scheduling of advertisements, e.g., auctioning and scheduling advertisements for available time slots or spots only hours or even minutes before the occurrence of the time slot.

[0077] In one implementation, the provider agent 162 can communicate with the advertisement distribution engine 122 to determine whether advertisements are available for storage on the local store 166. In one implementation, the provider agent 162 can poll the advertisement distribution engine 122 periodically, e.g., daily, weekly, etc. In another implementation, the advertisement distribution engine 122 can send a notification to the provider agent 162 when an advertisement is available for download, e.g., in response to the provider 160 approving one or more advertisements.

[0078] If advertisements are available for download, the advertisement distribution engine 122 can direct the provider agent 162 and a video streamer, e.g., the video steamer 212, to establish a communication session for downloading the advertisements from the advertisement store 102 to the local store 166. Additional data can also be downloaded, e.g., an advertisement identifier, or other advertisement parameters, e.g., stored in the advertisement parameter store 104. Upon a successful completion of the download, the provider agent 162 can send an acknowledgement signal to the advertisement distribution engine 122. The acknowledgment signal can, for example, be utilized to associate an advertisement with a television provider location, and to indicate that the television advertisement is stored in a local store 166 at the locus of the provider 160.

[0079] In one implementation, the advertisement distribution engine 122 can evaluate advertisement parameters stored in the advertisement parameter store 104 to determine to which providers 160 the advertisements should be distributed. For example, if the advertisement parameters specify that an advertisement is related to a California marketing campaign, the advertisement will only be distributed to providers 160 that service the California market.

[0080] In one implementation, the advertisement can be transcoded by the advertisement system 100 into a presentation format specified by the provider 160. In another implementation, the provider 160 can receive the advertisement in a standard format, e.g., and MPEG format, and transcode the advertisement into a suitable presentation format.

[0081] In another implementation, the advertisements can be streamed from the television advertising system 100 to the provider 162 in near-real time or during air time. Accordingly, the advertisements need not be stored in a local data store 166.

[0082] FIG. 4 is a block diagram of an example television advertisement scheduling and reporting system 400. The television advertisement scheduling and reporting system 400 can, for example, be implemented in the advertisement system 100 of FIG. 1.

[0083] In one implementation, the provider agent 162 can receive advertisement requests or advertisement availabilities in the form of an availability schedule 402. The availability schedule 402 can include a list of advertisement availabilities, e.g., time slots, corresponding contexts, e.g., television programs, the advertisement availability type, e.g., a single spot or a pod of several spots; and other data, such as geographic data, provider identification data, network data, etc.

[0084] The availability schedule 402 can, for example, be provided periodically, e.g., on a weekly basis for a coming

week; or on a daily basis, or at near real-time or in real time. The provider agent 162 can, for example, communicate with a provider interface 170, such as an API for a data server managed by the provider 160. In another implementation, the provider interface 170 can be implemented in the provider agent 162.

[0085] The provider agent 162 can provide the availability schedule 402 to the scheduling engine 124 of the advertisement scheduling and reporting system 400. The scheduling engine 124 can, for example, communicate with the candidate engine 126 to identify candidate television advertisement data associated with advertisements that are eligible to fill the advertisement spots that are specified in the availability schedule 402. The candidate engine 128 can implement various targeting and/or filtering rules as described with respect to FIG. 1 above.

[0086] The scheduling engine 124 can select one or more television advertisements to air during the television advertisement availability defined in the availability schedule 402. The selection can be based on the availability schedule 402, e.g., the time slots and associated context, and the candidate television advertisement data. The context can be utilized to determine a relevancy score, and the relevancy score can be utilized to scale an auction result so that bids related to advertisements that are more relevant to the identified context are scaled higher than bids related to less relevant advertisements.

[0087] The scheduling engine 124 can utilize a Vickrey-style auction based on a cost per action, e.g., a cost per 1000 impressions, or a cost per network (\$5.00 on network M, \$6.00 on network Y), etc. multiplied by a quality score, e.g., a historical impression rate associated with the advertisement, such as a number of viewers that are determined to have viewed the advertisement divided by the total number of viewers that received the advertisement. Other factors that can be used to determine the quality score can be derived from the performance data stored in performance data store 108, e.g., the performance of a particular advertisement during particular programming, the probability that viewers will tune to another channel during an advertisement; the probability that viewers will fast-forward through the advertisement; etc.

[0088] For example, assume the candidate engine 126 identifies three advertisements suitable for a particular advertisement spot. The scheduling engine 124 may determine an auction rank of the advertisements by multiplying the maximum cost per action for the advertisements by the quality score of the advertisements. To illustrate, suppose the quality score (QS) of advertisements A, B, and C are "2," "3," and "1.2," respectively. The rank of advertisements A, B, and C can be determined as follows:

[0089] A: Rank=QS×maximum cost per action=2.0×\$5.00=10.00

[0090] B: Rank=QS×maximum cost per action=3.0×\$7.50=22.50

[0091] C: Rank=QS×maximum cost per action=1.2×\$10.00=12.00

[0092] The advertisers can thus be ranked as follows:

[0093] 1. B

[0094] 2. C

[0095] 3. A

[0096] Accordingly, the advertisement B would be selected and displayed during the advertisement spot. In one implementation, the actual cost an owner of the advertisement B

will pay per thousand impressions can be determined by the subsequent advertisement rank (C) divided by the score of the advertisement B, e.g., $12/3=\$4.00$. Other auction processes can also be used.

[0097] In another implementation, for a set of advertisement spots, e.g., a pod of several 30-second advertisement spots, each spot can be auctioned separately. In another implementation, an entire pod can be auctioned, and the highest ranked advertisements can be selected for showing during the pod. For example, if the auction illustrated above for advertisements A, B and C was conducted for a pod of two advertisement spots, commercials B and C would be selected.

[0098] In one implementation, an impression rate can be set to an initial default value, e.g., a rate equal to an aggregate impression rate for advertisements in a related demographic or targeting area, and can thereafter be modified based on historical performance.

[0099] In an implementation, the scheduler engine 124 and/or the candidate engine 128 can enforce advertisement restrictions. For example, the scheduler engine 124 and/or the candidate engine 126 can filter the advertisements to eliminate unwanted advertisements, e.g., competitive restrictions can be applied so that one advertisement cannot be placed near another advertisement of a competitor. For example, a television advertisement availability window for an advertisement spot can be generated. The advertisement availability window can be time based, e.g., five minutes, or can be advertisement based, e.g., three advertisement spots prior to the advertisement spots and three advertisement spot subsequent to the advertisement spot. Advertisements that have associated competitive restrictions that are exclusive of the competitive restrictions of the television advertisements that are selected to air during the television advertisement availability window can thus be precluded from selection for that availability window. For example, if company A and company B are direct competitors for the same product, and an advertisement slot is available for auction, an advertisement for company B may only be eligible to auction if an advertisement for company A has not or will not air during the associated advertisement availability window e.g., within a predetermined number of advertisement slots or predetermined amount of time.

[0100] Frequency capping can be performed to limit the scheduling of certain advertisements based on an amount of time since the advertisement was last aired. For example, frequency values associated with the television advertisements can be recorded, e.g., the rate of showings of the advertisements per hour. If a current frequency value of an advertisement exceeds a repetition threshold, the advertisement may be precluded from being shown during an advertisement availability.

[0101] Likewise, geographic data can be used to filter local advertisements. For example, the availability schedule may define an advertisement availability in San Francisco, Calif. Accordingly, targeted local advertisements that are not targeted to San Francisco, e.g., a local car dealership in Los Angeles, Calif., may be precluded from being shown during an advertisement availability for the locality of San Francisco.

[0102] Once the advertisements are selected for an advertisement availability, data related to the selected advertisements and intended display times, e.g. advertisement identifiers and corresponding time slots that the corresponding advertisements are to be shown, can be provided to the pro-

vider 160 as an advertisement schedule 404. The advertisement schedule 404 can be accessed by an inserter 172 and a modulator 174 that are utilized to insert advertisements stored in the local store 166 into a broadcast stream 176.

[0103] A verification report 408 that includes data indicating whether the advertisement aired can be provided to the provider agent 162. In one implementation, the verification report 406 includes data that indicates whether the advertisement aired, the air time of the advertisement, and the channel on which the advertisement aired. The provider agent 162 can, in turn, transmit the verification report 406 to the television advertisement scheduling and reporting system 400 for processing by the reporting engine 128 and storing in the accounting data 112. Depending on contractual obligations, e.g., whether the advertisers are billed according to impressions or are charged a flat fee, the accounting engine 130 may then charge any fees due to the corresponding advertiser account.

[0104] In another implementation, data related to actual viewings, e.g., impression data 408, can be provided to the provider 160. The impression data 408 can, in turn, be provided to the provider agent 162 as an impression data report 410. The impression data report 410 can be provided to the reporting engine 128 for processing to determine an impression value related to the actual and/or estimate of the number of impressions. The impression value can be used by the accounting engine 130 to charge any fees due to the corresponding advertiser account.

[0105] In one implementation, the impression data 408 can be defined by viewing device 164 logs, e.g., set top box activity data. For example, user activity, including channel changes and timestamps, can be recorded and provided to the provider 160 periodically, e.g., daily or weekly, in the form of logs. The logs can, for example, be processed by the reporting engine 128 so that the timestamps are correlated to the times of advertisement insertions. In one implementation, each viewing device 164 that was tuned to a broadcast stream during a time at which an advertisement was inserted is counted as an impression. Additionally, other impression data can also be determined, such as tune-in and tune-away times for partial views of an advertisement. As the log data can effectively measure impressions for tuned televisions, multiple impressions can be generated per household.

[0106] In another implementation, a caching layer 420 can be utilized to cache data related to advertisement selection and processing of advertisement requests. The caching layer 420 can, for example, be utilized to optimize performance of the auctioning process.

[0107] In one implementation, the provider agent 162 can anonymize data related to particular viewing devices 164 and account information before the data are received by the television advertising scheduling and reporting system 400. Each viewing device 164 can be represented as an anonymous entity, and account information can be associated with a location information that has no more granularity than a zip code.

[0108] In another implementation, the impression data 408 can be defined by statistical measurements, e.g., by local and/or regional sampling and extrapolation to a viewership estimate, and can be provided by a third party. For example, Nielsen ratings data can be used to determine a viewership estimate and corresponding impression estimate.

[0109] In another implementation, advertisements can be targeted to video-on-demand users, digital video recorder

users, and the like. Accordingly, the advertisement scheduling data 404 can include real time or near real time requests.

[0110] FIGS. 5-9 are example television advertisement front end environments. The front end environments of FIGS. 5-9 can, for example, be implemented as a web-based user interface for advertisers 140 to the advertising system 100. Other front end environments, however, can also be used. The front end environments of FIGS. 5-9 can be utilized to provide advertisements to the television advertisement system 100, and to provide television advertisement parameters and other data for association with the advertisements.

[0111] FIG. 5 is a screen shot of an example targeting area environment 500, as indicated by the highlighted "Targeting Areas" setup stage on the setup menu 502. A campaign name can be entered in a campaign name field 504. A campaign can, for example, be a set of advertisements that are subject to a particular advertising rule set, e.g., a set of advertisements that share a common target demographic, for example.

[0112] An Ad Group can be defined in an Ad Group name field. An Ad Group can, for example, be a subset of a campaign. For example, a nation wide advertisement campaign can be divided into regional Ad Groups, e.g., Boston, Los Angeles, Seattle, etc.

[0113] An Available Areas frame 508 can be browsed to select available areas to target the advertisement campaign, and a Selected Areas frame 510 can display selected areas for the campaign. As shown in FIG. 5, available areas are divided into state regions. Additional geographic areas can be loaded into the Available Areas frame 508 by selecting an additional area, e.g., a state, in the Additional Areas frame 512.

[0114] A navigation button 514 can be selected to continue to the next advertisement front end environment, an advertisement creation and upload environment 600.

[0115] FIG. 6 is a screen shot of an example advertisement creation and upload environment 600, as indicated by the highlighted "Create/Upload Ad" setup stage on the setup menu 502. An advertisement type can be selected from an advertisement menu 602. For example, the advertisement menu 602 can be utilized to create and/or upload a text advertisement, e.g., a ticker advertisement that can be shown on the bottom or the side of a television screen; an image advertisement, such as a logo overlay; and a video advertisement, such as a television commercial.

[0116] Advertisement specifications 604 required for uploading an advertisement to the television advertisement system 100 can be displayed beneath a selected advertisement type. For example, the advertisement specifications 604 for a video advertisement 602 are shown.

[0117] Navigation buttons 608 can be selected to return to the previous advertisement front end environment 500, or to continue to the next advertisement front end environment, a targeting advertisement environment 700.

[0118] FIG. 7 is a screen shot of an example targeting advertisement environment 700, as indicated by the highlighted "Target Ad" setup stage on the setup menu 502. One or more broadcast networks or stations can be selected from list of broadcast stations 702 carried by a provider, e.g. provider 160, for showing advertisements in a campaign.

[0119] Scheduling data can be displayed on, for example, a weekly basis, as indicated by the weekday list 704. Each weekday can have associated eligibility times 706, e.g., times during which the advertiser desires the advertisement to be aired. A status indicator 708 can indicate a current status of a particular weekday status, e.g., "Running all hours," or "Run-

ning afternoon and early evening,” etc. An edit menu **710** can be utilized to edit associated eligibility times **706** for a particular weekday.

[0120] Navigation buttons **712** can be selected to return to the previous advertisement front end environment **800**, or to continue to the next advertisement front end environment, a pricing environment **800**.

[0121] FIG. **8** is a screen shot of an example pricing environment **800**, as indicated by the highlighted “Set Pricing” setup stage on the setup menu **502**. Budget data, such as weekly spend data, can be input into a budget field **802**. In one implementation, the budget data can be utilized to ensure that an advertiser budget is not exceeded during a specified period.

[0122] A cost per action, e.g., a cost per thousand impressions, can be input in a cost per action field **804**. In one implementation, the cost per action can be a maximum cost per action that an advertiser is willing to pay for a particular action. Other costs per actions can also be used, e.g., a cost per slot, etc.

[0123] Navigation buttons **806** can be selected to return to the previous advertisement front end environment **700**, or to continue to the next advertisement front end environment, a review environment **900**.

[0124] FIG. **9** is a screen shot of an example review environment **900**, as indicated by the highlighted “Review and Save” setup stage on the setup menu **502**. The review environment **900** summarizes the advertisements parameters entered by an advertiser during the process of creating an advertisement campaign. A parameter summary **902** can, for example, summarize advertisement parameters, such as the campaign name, target languages, national, regional and local locations of the target customers/viewers, and a weekly budget.

[0125] An Ad Group summary **904** can also be displayed, if applicable. As shown in FIG. **9**, an Ad group summary **904** displays a still image of one or more advertisements in the Ad group, a list of target networks, and a cost per action for the advertisements in the Ad group.

[0126] Navigation buttons **906** can be selected to return to the previous advertisement front end environment **800**, create another Ad group, or save the campaign.

[0127] FIG. **10** is a flow diagram of an example process **1000** of selecting television advertisements for advertisement availability. The process **1000** can, for example, be implemented in the advertisement system **100** of FIG. **1** and/or the television advertisement scheduling and reporting system **400**.

[0128] Stage **1002** identifies television advertisement availability. For example, the scheduler engine **124** can receive advertisement availability data from a television provider **160** and identify advertisement availabilities, such as advertisement spots.

[0129] Stage **1004** identifies a context associated with the television advertisement availability. For example, the scheduler engine **124** and/or the candidate engine **126** can identify a context, e.g., a program type associated with an advertisement availability, based on the advertisement availability data, or based on other data that can be searched according to parameters specified in the advertisement availability data, e.g. the advertisement availabilities can be cross-referenced with programming and channel guide information provided by third parties.

[0130] Stage **1006** receives television advertisement parameters associated with television advertisements. For

example, the scheduler engine **124** and/or the candidate engine **126** can receive television advertisement parameters from the advertisement parameter data store **104**. The advertisement parameters can be selected based on one or more filtering rules, based on the identified context, or by some other process.

[0131] Stage **1008** selects one or more television advertisements to air during the television advertisement availability based on the television advertisement availability, the context, and the advertisement parameters. For example, the scheduler engine **124** can perform an auction to select the highest ranked advertisements.

[0132] FIG. **11** is a flow diagram of an example process **1100** for restricting television advertisements. The process **1100** can, for example, be implemented in the advertisement system **100** of FIG. **1** and/or the television advertisement scheduling and reporting system **400**.

[0133] Stage **1102** identifies a television advertisement availability window for the television advertisement availability. For example, the scheduler engine **124** and/or the candidate engine **126** can identify a television advertisement availability window that is advertisement based, e.g., defined by adjacent advertisement spots, or time based, e.g., defined by a time window.

[0134] Stage **1104** identifies competitive restrictions associated with television advertisements that are selected to air during the television advertisement availability window. For example, the scheduler engine **124** and/or the candidate engine **126** can identify competitive restrictions stored in the advertisement parameter data store **104** advertisements currently selected to air during the television advertisement availability window.

[0135] Stage **1106** precludes selection of television advertisements having associated competitive restrictions that are exclusive of the competitive restrictions of the television advertisements that are selected to air during the television advertisement availability window. For example, the scheduler engine **124** and/or the candidate engine **126** may preclude selection of advertisements for company B if an advertisement for company A, a direct competitor, has aired or will air during the advertisement availability window.

[0136] FIG. **12** is a flow diagram of an example process **1200** for auctioning advertisement spots for television advertisements. The process **1200** can, for example, be implemented in the advertisement system **100** of FIG. **1** and/or the television advertisement scheduling and reporting system **400**.

[0137] Stage **1202** identifies advertisement time slots. For example, the scheduler engine **124** can receive advertisement availability data from a television provider **160** and identify advertisement time slots.

[0138] Stage **1204** identifies a television advertisement cost per action parameter for each television advertisement. For example, the scheduling engine **124** and/or the candidate engine **126** can access the advertisement parameters **104** and identify advertisement cost per action parameters.

[0139] Stage **1206** auctions the advertisement time slots based on the cost per action parameters. For example, the scheduler engine **124** can perform an auction based on the cost per action parameters.

[0140] Stage **1208** selects one or more television advertisements to air during the advertisement time slots based on the

auction. For example, the scheduler engine 124 can select one or more advertisement based on the resulting auction rank of the advertisements.

[0141] FIG. 13 is a flow diagram of an example process for auctioning 1300 advertisement spots based on a cost parameter and a quality parameter. The process 1300 can, for example, be implemented in the advertisement system 100 of FIG. 1 and/or the television advertisement scheduling and reporting system 400.

[0142] Stage 1302 identifies contexts associated with the advertisement time slots. For example, the scheduler engine 124 and/or the candidate engine 126 can identify a context based on a program type associated with an advertisement availability; or based on the advertisement time slot; or based on the broadcast network; or based on close-captioned text; or based on other data that can be searched according to the advertisement time slot, e.g. the advertisement availabilities can be cross-referenced with programming and channel guide information.

[0143] Stage 1304 determines a relevance measure for each advertisement based on the identified contexts and the targeting parameters. For example, the scheduler engine 124 and/or the candidate engine 126 can access the targeting parameters of an advertisement and determine whether the corresponding advertisement is relevant to the context.

[0144] Stage 1306 auctions the advertisement time slots based on a function of the cost per action parameter and the relevance measure for each advertisement. For example, the scheduler engine 124 can auction the advertisements based on a function of the cost per action parameter and the relevance measure so that advertisements that are more relevant to a context can be positively adjusted in an auction ranking.

[0145] In another implementation, advertisements can be auction solely on a cost per action parameter and a performance measure. For example, advertisers may desire to air commercials for a particular program with regard to context, such as an extremely popular sporting event for which ratings are projected to be very high across all demographics. Accordingly, the context can be ignored in some auction processes.

[0146] FIG. 14 is a flow diagram of an example process 1400 for receiving and distributing advertisements from advertisers. The process 1400 can, for example, be implemented in the advertisement system 100 of FIG. 1 and/or the television advertisement front end system 200 of FIG. 2 and the television advertisement distribution system 300 of FIG. 3.

[0147] Stage 1402 receives advertisement parameters from advertisers. For example, the advertisement front end engine 120 or advertisement front end interface 202 can receive advertisement parameters from an advertiser.

[0148] Stage 1404 receives television advertisements from the advertisers. For example, the advertisement front end engine 120 or advertisement front end interface 202 can receive television advertisements from the advertisers.

[0149] Stage 1406 associates the advertisement parameters with the television advertisements. For example, the advertisement front end engine 120 or advertisement front end interface 202 can store the advertisements and advertisement parameters in the advertisement data store 102 and the advertisement parameter data store 104 as associated data.

[0150] Stage 1408 identifies the television advertisements as pending approval. For example, the approval engine 208

can identify any newly-stored advertisement in the advertisement data store 102 as pending approval.

[0151] Stage 1410 provides a television provider or a representative of the television provider access to the television advertisements pending approval. For example, the approval engine 208 can provide a television provider access to the television advertisements pending approval so that the provider can review the advertisements. The television advertisements or access to the television advertisements can, for example, be stored in the approval bin 210.

[0152] Stage 1412 receives from the television provider approvals or disapprovals for the television advertisements pending approval. For example, the approval engine 208 can receive from the television provider approval data or disapproval data related to the advertisements pending approval.

[0153] Stage 1414 provides the approved television advertisements to the television provider. For example, the advertisement distribution engine 122 and the video streamer 212 can provide the approved television advertisements to the provider 160.

[0154] FIG. 15 is a flow diagram of an example process 1500 for providing auction results to a television provider. The process 1500 can, for example, be implemented in the advertisement system 100 of FIG. 1 and/or the television advertisement scheduling and reporting system 400.

[0155] Stage 1502 identifies advertisement time slots of the television provider. For example, the scheduler engine 124 can receive advertisement availability data from a television provider 160 and identify advertisement time slots.

[0156] Stage 1504 auctions the advertisement time slots based on the television parameters. For example, the scheduler engine 124 can auction the advertisement time slots according to the advertisement parameters stored in the parameter data store 104 and other data, such as performance data stored in the performance data store 108.

[0157] Stage 1506 selects one or more television advertisements to air during the advertisement time slots based on the auction. For example, the scheduler engine 124 can select the highest ranked advertisements of an auction for airing during the advertisement time slots.

[0158] Stage 1508 provides identification of the selected television advertisements to air during the advertisement time slots to the television provider. For example, the scheduler engine 124 can provide advertisement identifiers of the advertisements selected in stage 1506 to the provider 160.

[0159] The apparatus, methods, flow diagrams, and structure block diagrams described in this patent document may be implemented in computer processing systems including program code comprising program instructions that are executable by the computer processing system. Other implementations may also be used. Additionally, the flow diagrams and structure block diagrams described in this patent document, which describe particular methods and/or corresponding acts in support of steps and corresponding functions in support of disclosed structural means, may also be utilized to implement corresponding software structures and algorithms, and equivalents thereof.

[0160] Embodiments of the subject matter described in this specification can be implemented as one or more computer program products, i.e., one or more modules of computer program instructions encoded on a tangible program carrier for execution by, or to control the operation of, data processing apparatus. The computer readable medium can be a machine readable storage device, a machine readable storage

substrate, a memory device, a composition of matter effecting a machine readable propagated signal, or a combination of one or more of them.

[0161] A computer program (also known as a program, software, software application, script, or code) can be written in any form of programming language, including compiled or interpreted languages, or declarative or procedural languages, and it can be deployed in any form, including as a stand alone program or as a module, component, subroutine, or other unit suitable for use in a computing environment. A computer program does not necessarily correspond to a file in a file system. A program can be stored in a portion of a file that holds other programs or data (e.g., one or more scripts stored in a markup language document), in a single file dedicated to the program in question, or in multiple coordinated files (e.g., files that store one or more modules, sub programs, or portions of code). A computer program can be deployed to be executed on one computer or on multiple computers that are located at one site or distributed across multiple sites and interconnected by a communication network.

[0162] The processes and logic flows described in this specification can be performed by one or more programmable processors executing one or more computer programs to perform functions by operating on input data and generating output. The processes and logic flows can also be performed by, and apparatus can also be implemented as, special purpose logic circuitry, e.g., an FPGA (field programmable gate array) or an ASIC (application specific integrated circuit).

[0163] Processors suitable for the execution of a computer program include, by way of example, both general and special purpose microprocessors, and any one or more processors of any kind of digital computer. Generally, a processor will receive instructions and data from a read only memory or a random access memory or both. The essential elements of a computer are a processor for performing instructions and one or more memory devices for storing instructions and data. Generally, a computer will also include, or be operatively coupled to receive data from or transfer data to, or both, one or more mass storage devices for storing data, e.g., magnetic, magneto optical disks, or optical disks. However, a computer need not have such devices.

[0164] To provide for interaction with a user, embodiments of the subject matter described in this specification can be implemented on a computer having a display device, e.g., a CRT (cathode ray tube) or LCD (liquid crystal display) monitor, for displaying information to the user and a keyboard and a pointing device, e.g., a mouse or a trackball, by which the user can provide input to the computer. Other kinds of devices can be used to provide for interaction with a user as well; for example, feedback provided to the user can be any form of sensory feedback, e.g., visual feedback, auditory feedback, or tactile feedback; and input from the user can be received in any form, including acoustic, speech, or tactile input.

[0165] Embodiments of the subject matter described in this specification can be implemented in a computing system that includes a back end component, e.g., as a data server, or that includes a middleware component, e.g., an application server, or that includes a front end component, e.g., a client computer having a graphical user interface or a Web browser through which a user can interact with an implementation of the subject matter described is this specification, or any combination of one or more such back end, middleware, or front end components. The components of the system can be interconnected by any form or medium of digital data communication,

e.g., a communication network. The computing system can include clients and servers. A client and server are generally remote from each other and typically interact through a communication network. The relationship of client and server arises by virtue of computer programs running on the respective computers and having a client server relationship to each other.

[0166] While this specification contains many specific implementation details, these should not be construed as limitations on the scope of any invention or of what may be claimed, but rather as descriptions of features that may be specific to particular embodiments of particular inventions. Certain features that are described in this specification in the context of separate embodiments can also be implemented in combination in a single embodiment. Conversely, various features that are described in the context of a single embodiment can also be implemented in multiple embodiments separately or in any suitable subcombination. Moreover, although features may be described above as acting in certain combinations and even initially claimed as such, one or more features from a claimed combination can in some cases be excised from the combination, and the claimed combination may be directed to a subcombination or variation of a subcombination.

[0167] Similarly, while operations are depicted in the drawings in a particular order, this should not be understood as requiring that such operations be performed in the particular order shown or in sequential order, or that all illustrated operations be performed, to achieve desirable results. In certain circumstances, multitasking and parallel processing may be advantageous. Moreover, the separation of various system components in the embodiments described above should not be understood as requiring such separation in all embodiments, and it should be understood that the described program components and systems can generally be integrated together in a single software product or packaged into multiple software products.

[0168] This written description sets forth the best mode of the invention and provides examples to describe the invention and to enable a person of ordinary skill in the art to make and use the invention. This written description does not limit the invention to the precise terms set forth. Thus, while the invention has been described in detail with reference to the examples set forth above, those of ordinary skill in the art may effect alterations, modifications and variations to the examples without departing from the scope of the invention.

What is claimed is:

1. A computer-implemented method, comprising:
 - identifying a television advertisement availability;
 - identifying a context associated with the television advertisement availability;
 - receiving television advertisement parameters associated with television advertisements; and
 - selecting one or more television advertisements to air during the television advertisement availability, the selection based on the television advertisement availability, the context, and the advertisement parameters.
2. The method of claim 1, wherein:
 - identifying a context associated with the television advertisement availability comprises:
 - identifying a television program associated with the television advertisement availability.

3. The method of claim 1, wherein: receiving television advertisement parameters associated with television advertisements comprises: receiving cost per action parameters associated with the television advertisements.
4. The method of claim 3, wherein: the cost per action parameters comprise a cost per impression value.
5. The method of claim 4, wherein: selecting one or more television advertisements to air during the advertisement availability comprises: auctioning the advertisement availability based on the cost per impression value.
6. The method of claim 1, wherein: receiving television advertisement parameters associated with television advertisements comprises receiving frequency values associated with the television advertisements; and selecting one or more television advertisements to air during the advertisement availability comprises precluding selection of television advertisements having associated frequency values that exceed a repetition threshold.
7. The method of claim 1, wherein: receiving television advertisement parameters associated with television advertisements comprises receiving competitive restrictions associated with the advertisements; and selecting one or more television advertisements to air during the advertisement availability comprises: identifying a television advertisement availability window for the television advertisement availability; identifying the competitive restrictions associated with television advertisements that are selected to air during the television advertisement availability window; and precluding selection of television advertisements having associated competitive restrictions that are exclusive of the competitive restrictions of the television advertisements that are selected to air during the television advertisement availability window.
8. The method of claim 1, wherein: receiving television advertisement parameters associated with television advertisements comprises receiving advertising budget data associated with the advertisements; and selecting one or more television advertisements to air during the advertisement availability comprises: restricting selection of television advertisements based on the budget data.
9. The method of claim 1, comprising: receiving television advertisement parameters associated with television advertisements comprises receiving geographic data associated with the television advertisements; and selecting one or more television advertisements to air during the advertisement availability comprises precluding selection of television advertisements based on the geographic data.
10. The method of claim 1, comprising: receiving a television advertisement report; and determining whether the selected one or more television advertisements aired during the television advertisement availability based on the television advertisement report.
11. The method of claim 1, comprising: providing the television advertisements to a television provider prior to the television advertisement availability.
12. The method of claim 11, comprising: associating television advertisement identifiers with the television advertisements; and providing the television advertisement identifiers of the selected one or more television advertisements to the television provider.
13. The method of claim 1, wherein: the television advertisement availability comprises a television advertisement pod.
14. The method of claim 1, wherein: the television advertisements comprise television commercials.
15. The method of claim 1, wherein: the television advertisements comprise overlays,
16. The method of claim 1, wherein: the television advertisements comprise text streams.
17. The method of claim 1, wherein: identifying a context associated with the television advertisement availability comprises: identifying a television network associated with the television advertisement availability.
18. The method of claim 1, wherein: the impression value is based on a percentage of advertisement exposure.
19. A system, comprising: a television advertisement scheduling device configured to: receive a television advertisement request from a television provider, the television advertisement request defining television advertisement availability; issue a request for candidate television advertisement data based on the television advertisement request; receive candidate television advertisement data in response to the request for candidate television advertisement data; and select one or more television advertisements to air during the television advertisement availability, the selection based on the television advertisement request and the candidate television advertisement data.
20. The system of claim 19, comprising: a television advertisement candidate device configured to: store television advertisement data associated with television advertisements; receive the request for candidate television advertisement data from the television advertisement scheduling device; identify candidate television advertisement data in response to the request for candidate television advertisement data, the identification based on the television advertisement data; and provide the candidate television advertisement data to the television advertisement candidate device.
21. The system of claim 20, wherein: the television advertisement data comprise one or more of budget data associated with the television advertisements, cost per action data associated with the television advertisements, quality data associated with the television advertisements, or targeting data associated with the television advertisements.

22. The system of claim **21**, wherein:
the television advertisement scheduling device is configured to auction the advertisement availability based on the cost per action data associated with the television advertisements.

23. The system of claim **21**, wherein:
the cost per action data defines a maximum payment per impression;
the quality data defines an impression rate; and
the television advertisement scheduling device is configured to auction the advertisement availability based on the maximum payment per impression multiplied by the impression rate for each television advertisement.

24. The system of claim **20**, comprising:
a television advertisement verification device configured to:
receive television advertisement report data; and
determine whether the selected television advertisements aired based on the television advertisement report data.

25. The system of claim **24**, comprising:
a television provider agent distributable to television providers, each television provider agent configured to:
provide television advertisement requests for a television provider to the television advertisement scheduling device; and
provide television advertisement report data for the television provider to the television advertisement verification device.

26. A computer-implemented method, comprising:
identifying advertisement time slots;
identifying television advertisement parameters associated with television advertisements, the television advertisement parameters including a cost per action parameter for each television advertisement;
auctioning the advertisement time slots based on the cost per action parameters; and
selecting one or more television advertisements to air during the advertisement time slots based on the auction.

27. The method of claim **28**, wherein:
the television advertisement parameters include a quality parameter for each television advertisement; and
auctioning the advertisement time slots based on the cost per action parameters comprises auctioning the adver-

tisement time slots based on a function of the cost per action parameter and the quality parameter for each advertisement.

28. The method of claim **27**, wherein:
the cost per action parameter comprises a maximum cost per impression; and
the quality parameter comprises an impression parameter.

29. The method of claim **28**, wherein:
the television advertisement parameters include targeting parameters for each advertisement.

30. The method of claim **29**, comprising:
identifying contexts associated with the advertisement time slots; and
determining a relevance measure for each advertisement based on the identified contexts and the targeting parameters.

31. The method of claim **29**, wherein:
auctioning the advertisement time slots based on the cost per action parameters comprises auctioning the advertisement time slots based on a function of the cost per action parameter and the relevance measure for each advertisement.

32. The method of claim **28**, wherein:
the television advertisement parameters include a restriction parameter for each television advertisement; and
auctioning the advertisement time slots based on the cost per action parameters comprises auctioning the advertisement time slots based on the cost per action parameter and the restriction parameter for each advertisement.

33. The method of claim **32**, wherein:
the restriction parameter comprises a frequency capping parameter.

34. The method of claim **32**, wherein:
the restriction parameter comprises a competitive restriction parameter.

35. The method of claim **27**, wherein:
the cost per action parameter comprises a maximum cost per impression; and
the quality parameter comprises probability of viewer behavior.

36. The method of claim **35**, wherein:
the probability of viewer behavior comprises a probability of viewer tune out.

* * * * *